



# USE AND MAINTENANCE MANUAL







## **TABLE OF CONTENTS**

1. INTRODUCTION .....	5
1.1 MANUFACTURER.....	5
1.2 REVISION INDEX .....	5
1.3 GENERAL WARNINGS.....	5
1.4 KNOWLEDGE OF AND PRESERVING THE INSTRUCTION MANUAL .....	6
1.5 PREVENTIVE MEASURES BY THE USER.....	6
1.6 RECEIPT OF GOODS.....	7
1.7 LIFTING AND TRANSPORT.....	7
1.8 INTENDED USES AND FORBIDDEN USES .....	7
1.9 CONDITIONS OF USE.....	7
1.10 OIL REPLENISHMENT .....	8
1.11 REFUELLING.....	8
1.12 INSTALLATION .....	8
1.13 LIGHTING .....	8
1.14 NOISE.....	9
1.15 SIGNS.....	9
1.16 WARNING SYMBOLS ON THE MACHINE.....	9
1.17 STORAGE .....	10
1.18 REFERENCE REGULATIONS.....	10
1.19 RULES ON USE AND MAINTENANCE .....	11
1.20 WARRANTY .....	12
1.21 RESPONSIBILITY .....	12
1.22 DISPOSAL AND DEMOLITION.....	12
2. DESCRIPTION, FEATURES AND CHARACTERISTICS.....	13
2.1 CHARACTERISTICS OF THE MACHINE .....	13
2.2 DIMENSIONS.....	14
2.3 DESCRIPTION .....	15
2.4 RESIDUAL RISK.....	18
3. PRELIMINARY OPERATIONS.....	19
3.1 OPERATIONS BEFORE EACH USE.....	19
3.2 CONTROL PANEL .....	19
3.3 TRANSPORT .....	21
3.4 MACHINE POSITIONING.....	22
3.5 PREPARATION OF THE MACHINE FOR STRINGING.....	23
3.6 PERIODIC CHECK OF THE CABLE TENSION AT THE REWINDER.....	25

3.7	MACHINE STOP .....	25
3.8	ROPE WRAPPING.....	26
3.9	CABLE BLOCKAGE ON THE DRUM .....	27
3.10	SAFETY DEVICES.....	27
3.11	EMERGENCY STOP BUTTON .....	27
4.	MAINTENANCE .....	28
4.1	GENERAL RULES.....	28
4.2	ENDOTHERMIC MOTOR MAINTENANCE.....	28
4.3	HYDRAULIC CIRCUIT MAINTENANCE .....	28
4.4	REGENERATION .....	29
4.5	GREASING .....	30
4.6	OTHER PERIODICAL OPERATIONS.....	30
4.7	ORDINARY MAINTENANCE .....	31
5.	DESCRIPTION "HMI" MACHINE MANAGEMENT.....	33
5.1	"HMI" MACHINE RECORDING AND MANAGEMENT SYSTEM .....	33
5.2	PASSWORD .....	35
5.3	RADIO CONTROL DESCRIPTION.....	36
6.	HMI DESCRIPTION .....	38
6.1	MAIN PAGE .....	38
6.2	MENU .....	39
6.3	WORKING DATA.....	40
6.4	SUPERVISOR WORKING DATA.....	41
6.5	FILE MANAGER.....	42
6.6	DIESEL ENGINE SYNOPTIC.....	43
6.7	POWER LIMITER .....	44
6.8	ALARMS.....	45
6.9	HMI SETTINGS.....	46
7.	ATTACHED DOCUMENTS.....	47



## 1. INTRODUCTION

### 1.1 MANUFACTURER

TE.M.A. S.p.A.  
Via Prato Pieve, 48  
24060 Casazza  
Bergamo  
Italy  
Tel.: (+39) 035-812781  
Email: info@temaitaly.it

### 1.2 REVISION INDEX

REVISION	DATE	REVISED PART	AUTHORS	CHECKED	APPROVED
00	18/11/2024	/	Foresti Luca	RUT	RT

### 1.3 GENERAL WARNINGS

This manual contains all the information necessary for the use and maintenance of the TE.M.A. production winch.

Please follow these instructions to obtain the best results and correct operation of the machine. Before using the machine, it is necessary to be familiar with all the information contained in the use and maintenance manual.

Due to TE.M.A.'s continuous improvement program, the materials and specifications are subject to change without notice.



**It is absolutely forbidden to reproduce even part of the illustrations and/or the text.**



#### **1.4 KNOWLEDGE OF AND PRESERVING THE INSTRUCTION MANUAL**

- Before using the machine, the site manager and the operator are obliged to take note of the instruction manual. The information contained therein is addressed to all users and those in charge of machine maintenance.
- The site manager must make all operators aware of the instructions contained in the manual. In particular, before starting the machine, it is essential for the operator to be familiar with the positions and operation of all the controls. In addition to this, they must be able to perform all the operations described in this manual, making sure that they have clearly understood the safety regulations and are able to apply them correctly during use and/or maintenance. The operator must be aware of the Rules concerning the prevention of accidents.
- The site manager must check the application of the instructions contained in the manual.
- The instruction manual must be kept, for consultation, for the entire life of the machine even when it is transferred to another user.
- The instruction manual must be kept in a safe and dry place.
- The instruction manual is not a vocational training manual, i.e. its knowledge does not replace the level of professionalism required for the operator.

#### **1.5 PREVENTIVE MEASURES BY THE USER**

- Scrupulously observe the accident prevention regulations in force at the place of use.
- Observe all indications of danger and caution.
- Always use the personal protective equipment (PPE) required by the regulations in force in the place of use of the machine.
- The operator in charge of the installation, use and maintenance of the machine must wear clothing appropriate to the working environment and the situation in which it is located.
- Start the machine only when there are no unauthorised people in the installation area.
- The operator must not carry out operations or interventions on their own initiative that are not within their competence.
- The operator workstations must always be kept clear and clean of any oily, liquid and solid residues as well as equipment that may get in the way.
- It is mandatory to provide the user of the machine with adequate instruction and training of the operators involved in the use of the machine.



## 1.6 RECEIPT OF GOODS

Upon receipt of the machine, make sure that the packaging has not been damaged during transport and that it has not been tampered with, with the consequent possible removal of parts contained inside.

Contents of the packaging:

- Assembled machine
- Use and maintenance manual



**In the event of damage or missing parts, immediately notify TE.M.A. S.p.A. and the carrier, providing photographic documentation; after verification, if necessary, refuse the delivery note, have it countersigned by the carrier and notify, if possible via email, TE.M.A. S.p.A.**

## 1.7 LIFTING AND TRANSPORT

- To lift and transport the machine packed in a box or cage, use only a forklift truck or an overhead crane of adequate capacity with the help of chains equipped with hooks suitable for lifting. Any other system voids the insurance guarantee for any damage to the machine.
- To lift the unpacked machine, use only the appropriate hooking points highlighted (see fig.1).

## 1.8 INTENDED USES AND FORBIDDEN USES

The intended use of the machine is the laying of underground cables in pipes and trenches. For any use other than that envisaged, TE.M.A. shall not be held responsible for any defects or risks deriving from the use of the machine.

The machine **must not be used**:

- To lift people and/or goods.
- To handle trolleys or other mobile equipment.
- As a "brake" during stringing operations.
- With ropes or joints of a diameter other than that indicated in the manual.
- With the presence of unauthorised personnel in the work area.
- If the safety devices installed on the machine have been tampered with.

## 1.9 CONDITIONS OF USE

Environmental characteristics of the installation area:

- Temperature..... from 14°F to 113°F
- Relative humidity..... from 30% to 90% ( ± 5%)



## 1.10 OIL REPLENISHMENT

The machine is equipped with hydraulic drives which require **hydraulic oil to operate**. Check for the presence of this oil **before starting and using the machine**.

The characteristics and quantities required are indicated in this booklet. Use oil that complies with the technical specifications (see oil table).



**The use of oil that does not comply with the technical specifications indicated will damage the components of the hydraulic system and void the warranty.**

The endothermic engine as the power source of the machine requires lubrication oil, as indicated in the attached engine booklet.

## 1.11 REFUELLING

To refuel, use the nozzle (see fig.1) on the fuel tank.



**Refuelling must be carried out with the engine switched off (allow the engine to cool down for a few minutes before performing this operation).**



**Do not ingest oils, fuels, refrigerants etc. as they are harmful to personal health and safety.**

## 1.12 INSTALLATION

The main power for the operation of the machine is generated by an endothermic engine equipped with a liquid cooling system. To ensure its proper operation without reducing its performance, it is necessary to follow the following instructions:



**In the machine installation area, make sure that the cooling air can flow in and out freely.**



**The machine must not be used in environments that may present an explosion hazard due to the concentration of dangerous substances (gases, explosive dust, etc.).**



**The machine cannot be installed indoors.**

## 1.13 LIGHTING

Responsibility for the appropriate lighting of the workplace where the machine will be used is entrusted to the user, in accordance with current regulations and Community directives. The choice of lighting levels suitable for a certain type of environment or visual activity can be made on the basis of Standard UNI EN 1837.



### 1.14 NOISE

The machine is designed and manufactured in such a way as to reduce the sound power level at the source, with the use of an engine characterised by low noise. TE.M.A. informs the user of its noise emissions so that the latter can take appropriate measures according to the environmental operating conditions. It will therefore be the user's responsibility to prepare any suitable hearing protection in order to protect the operator as much as possible.

The detected sound power level of the winch is  $L_{wA}=94$  dB(A), thus complying with the limit imposed by Directive 2005/88/EC.

### 1.15 SIGNS

It is necessary to provide a boundary area around the machine (about 30 feet from the centre of the machine) within which only the presence of the operators necessary to ensure correct operation of the machine is allowed.

In addition to this, the place where the machine is used must feature general signs, specific to the characteristics of the premises and workplaces.

Example:

Handling, Danger zones, High voltage

### 1.16 WARNING SYMBOLS ON THE MACHINE





## **1.17 STORAGE**

In the event of a long period of inactivity, the machine must be stored in a clean and dry environment, possibly protected from direct sunlight according to the general technical specifications.



**TE.M.A. S.p.A. shall not be held responsible for any damage in the event that the user does not follow the above instructions.**

## **1.18 REFERENCE REGULATIONS**

- Machinery Directive 2006/42/EC.
- UNI EN ISO 12100:2010 (Safety of machinery - Fundamental concepts; general principles for design).
- UNI EN ISO 13857:2020 (Safety of machinery - Safety distances to prevent hazard zones being reached by upper and lower limbs).
- UNI EN ISO 13850: 2015 (Safety of machinery - Emergency stop function - Design principles).
- UNI EN ISO 13732-1:2009 (Ergonomics of the thermal environment - Methods for the assessment of human response to contact with surfaces - Part 1: Hot surfaces).
- UNI EN ISO 14120:2015 (Safety of machinery - Guards - General requirements for the design and construction of fixed and movable guards).
- EN 60204-1: 2018 (Safety of machinery - Electrical equipment Part 1: General requirements).



## 1.19 RULES ON USE AND MAINTENANCE



The machine must be used in accordance with the Manufacturer's specifications (technical specifications, safety specifications, etc.).



Do not modify parts of the machine for any reason: responsibility for interventions of any kind not authorised in writing by TE.M.A. S.p.A. lies with the person carrying out the work.



Any changes must be authorised by the Manufacturer. If the machine is used outside its limits of use or by altering its characteristics in any way, T.E.M.A. S.p.A. declines all responsibility.



It is strictly forbidden to carry out any maintenance, adjustment or setting on moving parts: before performing any of these operations, disconnect the power supply to be sure to operate safely.



It is strictly forbidden to remove or tamper with the safety devices.



When the machine is in operation, contact with any part of it is strictly forbidden.



Gloves must be worn when performing any operation involving the machine.



Respiratory protection is mandatory when near exhaust emissions.



Hearing protection must be worn near the machine.

## 1.14 ASSISTANCE AND SPARE PARTS SERVICE

Contact TE.M.A. S.p.A. - Tel.: (+39) 035-812781, Email: [info@temaitaly.it](mailto:info@temaitaly.it).



## 1.20 WARRANTY

- The machine supplied is guaranteed for a period of 12 months, starting from the date of shipment.
- The warranty is valid only if the machine is not working due to defects in materials, workmanship or a major construction defect. These defects must be immediately reported to TE.M.A. S.p.A. in writing, in the most detailed manner possible.
- The warrant commits T.E.M.A. S.p.A. to replace, free of charge, at its plant in Casazza (Bg), any components recognised as defective in manufacture and/or relative technical performance. Parts of the endothermic engine, for which the Manufacturer's warranty conditions apply, are excluded. The warranty does not cover materials and parts subject to natural wear or deterioration.
- The warranty expires if the machine has been tampered with, modified or repaired without authorisation.
- TE.M.A. S.p.A. shall not be held responsible for any direct or indirect damage caused by negligence, incorrect or improper use and installation, and in any case by phenomena not depending on the normal operation of the machine, as well as dents during transport.

In case of intervention by TE.M.A. S.p.A. outside the aforementioned warranty conditions, the machine must be returned, at the purchaser's expense and risk, to the headquarters of Casazza (Bg). For interventions at the customer's premises, the travel and accommodation expenses of the technical staff will be charged.

## 1.21 RESPONSIBILITY

The machine must **only** be used by trained and competent operators.  
The machine must **only** be used for the purpose for which it was designed.



**TE.M.A. S.p.A. shall not be held responsible for any damage if the machine is used for any other purpose not envisaged and in the cases indicated below:**

- Use by untrained personnel.
- Tampering and/or changes made without written approval.
- Use of non-original spare parts.
- Insufficient maintenance.
- Total or partial non-compliance with the instructions for use.

## 1.22 DISPOSAL AND DEMOLITION

When decommissioning, demolishing and disposing of the machine, or any individual parts of it, the user must comply with the rules and regulations in force in the country where the machine is used.



**For the disposal of special and toxic harmful waste, it is essential to contact specialised/authorised companies.**



## 2. DESCRIPTION, FEATURES AND CHARACTERISTICS

### 2.1 CHARACTERISTICS OF THE MACHINE

<b>Engine</b>	Yanmar
<b>Type</b>	Stage V / EPA tier 4 final
<b>Engine power (hp)</b>	36,5 hp
<b>Engine power (kW)</b>	27 kW
<b>Max pull</b>	11000 lb
<b>Max speed</b>	180 ft/min
<b>Max speed in max pull conditions</b>	39 ft/min
<b>Capstans</b>	Multi grooves capstans
<b>Capstans diameter</b>	Ø 11 inches bottom groove
<b>Max steel rope diameter</b>	Ø 0,55 inches (14 mm)
<b>Hydraulic oil</b>	ATF DEXRON II
<b>Hydraulic oil quantity</b>	18 gal
<b>Fuel tank capacity</b>	9 gal
<b>Reel capacity (feet)</b>	3280 feet rope Ø 1/2 inches (square)
<b>Reel capacity (lbs)</b>	1100 lbs rope
<b>Maximum allowable hydraulic oil temperature</b>	176°F
<b>Mass of the winch</b>	4630 lbs
<b>Optional features</b>	04-PW Radiocontrol



## 2.2 DIMENSIONS

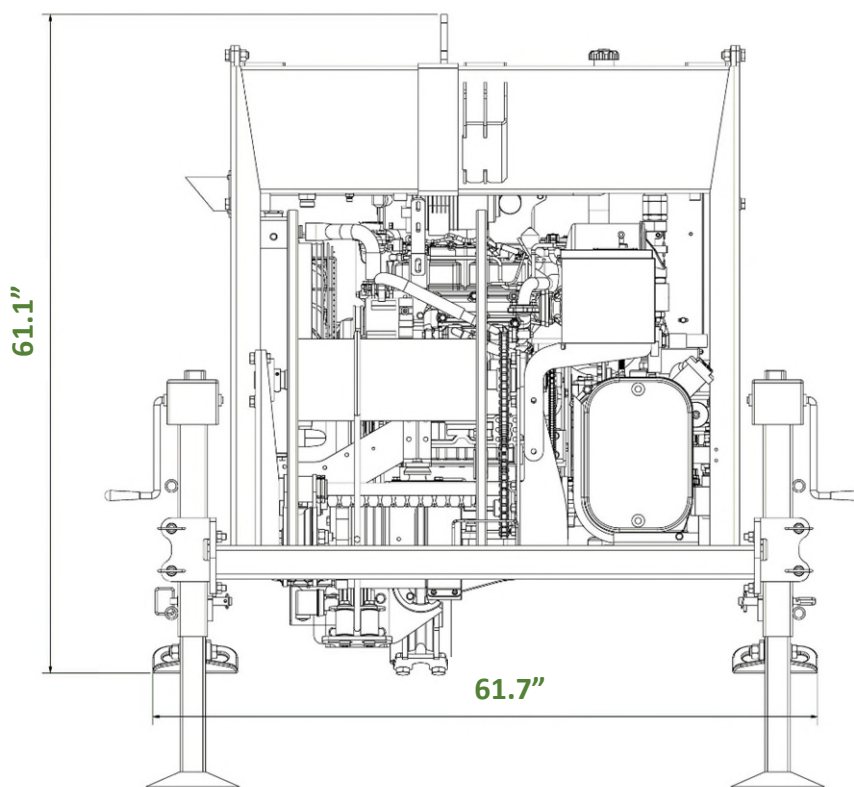
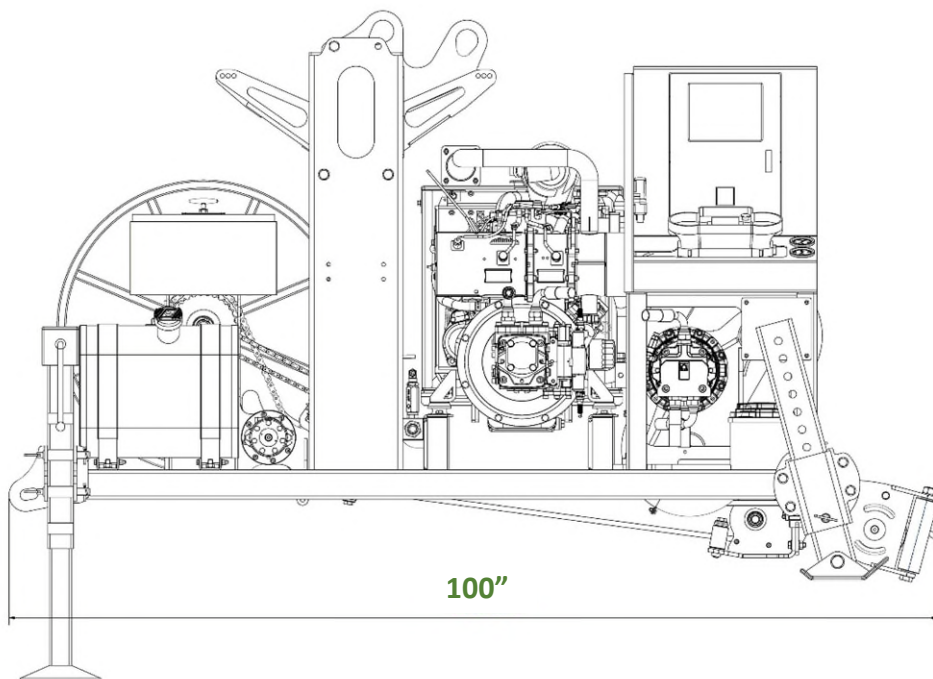



### 2.3 DESCRIPTION

The machine is supplied with an automatic rope winding device and is mounted on a frame equipped with attachment points for anchoring to the ground as well as a lifting point. A negative hydraulic brake guarantees automatic blocking of the drum every time the operator releases the control lever, or in the event of a hydraulic system failure.

For checking the functionality of the machine, the panel includes the following as standard:

- Digital HMI (human machine interface), control over the pull and the speed with a digital touch screen display and USB input;
- Data recording capability on internal memory, and work file extrapolation;
- The facility for setting work parameters;
- Integrated engine alarm monitoring system for control/protection of the machine.

<b>1</b>	REAR STABILISERS	<b>13</b>	LIFTING POINT
<b>2</b>	ROLLER GUIDING DEVICE	<b>14A</b>	LIFTING POINT WITH ROPE LOADED
<b>3</b>	FRONT STABILISERS	<b>14B</b>	LIFTING POINT WITHOUT ROPE
<b>4</b>	CONTROL PANEL WITH HMI	<b>15</b>	DRUM
<b>5</b>	CONTROL PANEL DOOR	<b>16</b>	AUTOMATIC ROPE WINDING DEVICE
<b>6</b>	FUEL FILLER CAP	<b>17</b>	CHAIN TENSIONER
<b>7</b>	HYDRAULIC OIL FILTER	<b>18</b>	CAPSTANS UNIT
<b>8</b>	MACHINE BONNET	<b>19</b>	MACHINE BONNET OPENING
<b>9</b>	OIL FILLER CAP	<b>20</b>	BATTERY
<b>10</b>	OIL LEVEL AND TEMPERATURE	<b>21</b>	TOOLS BOX
<b>11</b>	HYDRAULIC OIL DRAIN CAP	<b>22</b>	ENGINE
<b>12</b>	ANCHORAGE TO THE GROUND	<b>23</b>	REMOTE CONTROL

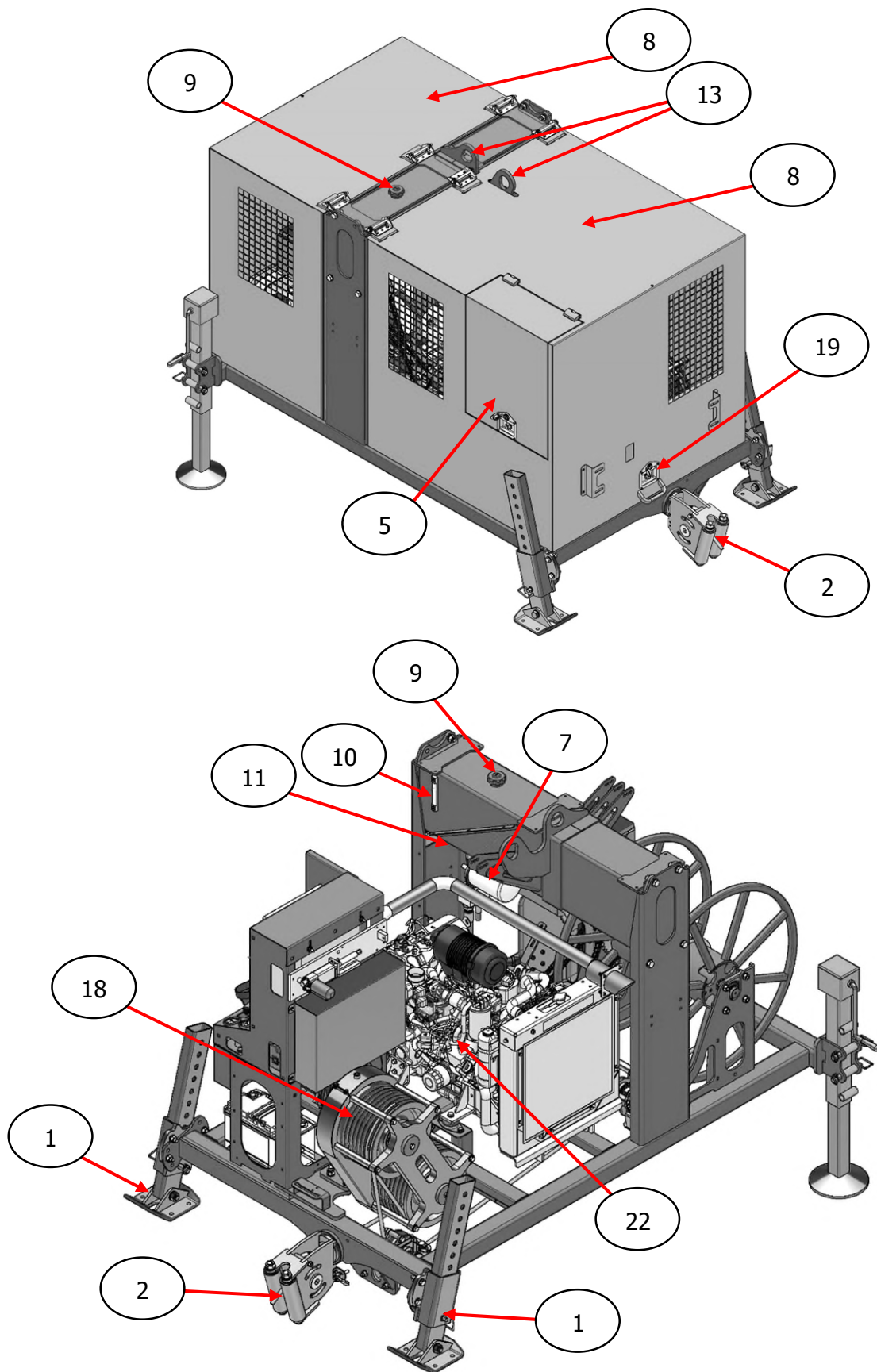

**FIG.1**

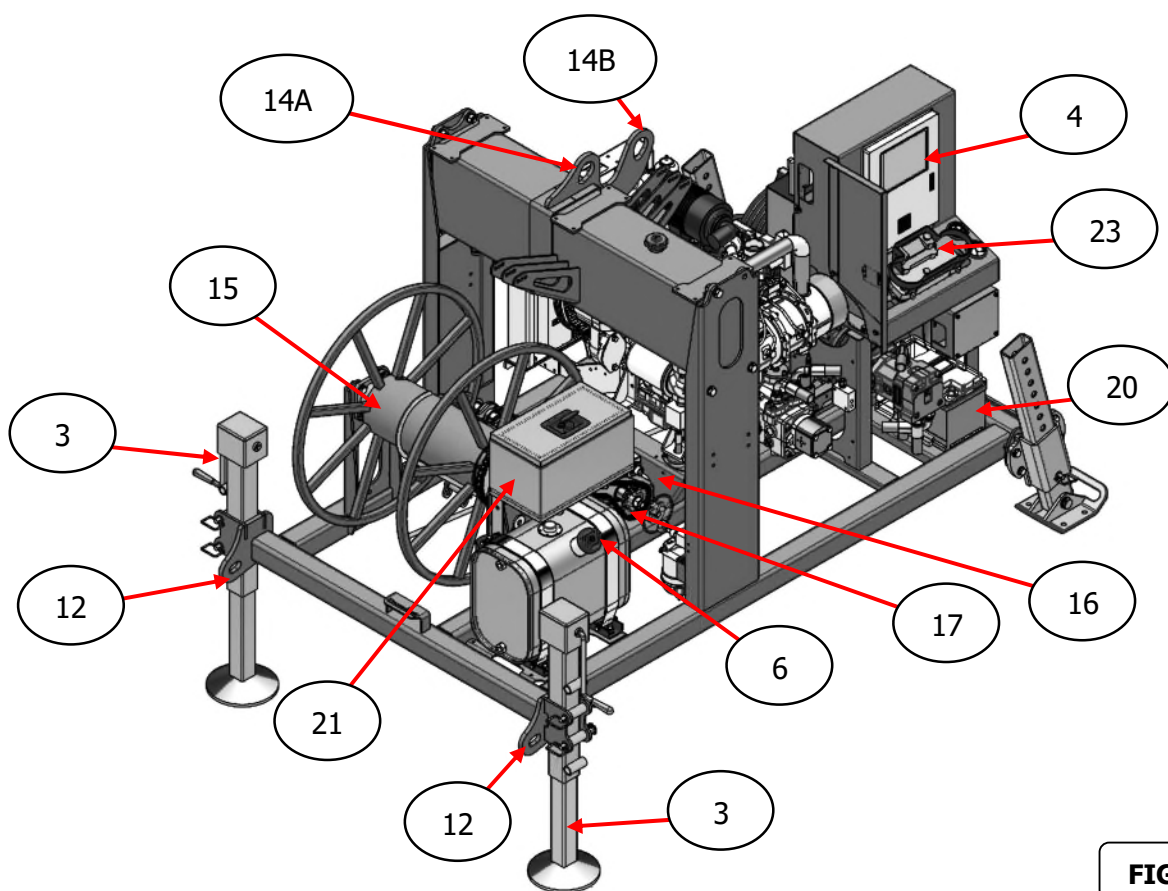

**FIG.1**



## 2.4 RESIDUAL RISK



The breaking of one of the anchoring strips can lead to the instability of the machine and to the sudden movements of the latter. To limit these problems, carefully follow the anchoring methods described in the operating instructions. However, it is useful to provide a boundary area around the machine (about 30 feet From the center of the machine) within which only the operators necessary to guarantee the correct operation of the machinery are allowed.



Any rope breakage outside the protected parts could cause sudden movements. To ensure the safety of personnel, it is advisable to set up an area within which unauthorized personnel cannot stop during machine operation.



The machine emits exhaust gases from the combustion of the endothermic engine. To minimize the risks, the operator must respect the working position at the winch control lever.



The machine does not provide for proper grounding, therefore during the laying operations dangerous concentrations of electrostatic charges can be generated on cables and conductors. To minimize risks, the operator must:

- Know the safety and accident prevention regulations in force and apply them strictly.
- Make sure that a suitable grounding measure of the machine system - tow rope - conductors has been provided at the construction site level.



During loading the rope onto the drum there is still a risk of problems such as:

- Improper unwinding of the rope, with consequent overlapping of the loops which can cause sudden collapse of the load during the shooting phases.
- Damage to the machine due to non-regular sliding of the rope in this phase, due to defects in its shape.



For technological reasons the machine does not have a limit switch. To minimize the risks, the operator must check the approaching of the filling and empty the drum and stop the machine. (To check the emptying a red colored band on the drum is provided as visual indication)



### 3. PRELIMINARY OPERATIONS

#### 3.1 OPERATIONS BEFORE EACH USE

Before carrying out any maneuver, check the oil level in the following points:

- Hydraulic oil tank (fig.1 pos.10)
- Endothermic engine (see attached engine manual)

We recommend that you always keep the hydraulic oil at the highest level.

In case of lack of oil top up, paying attention during filling so that no foreign bodies enter the oil, which could irreparably damage the components of the circuit.

Also provide for the greasing of the transmission chain, that of the winder and the screw of the winder itself.

#### 3.2 CONTROL PANEL

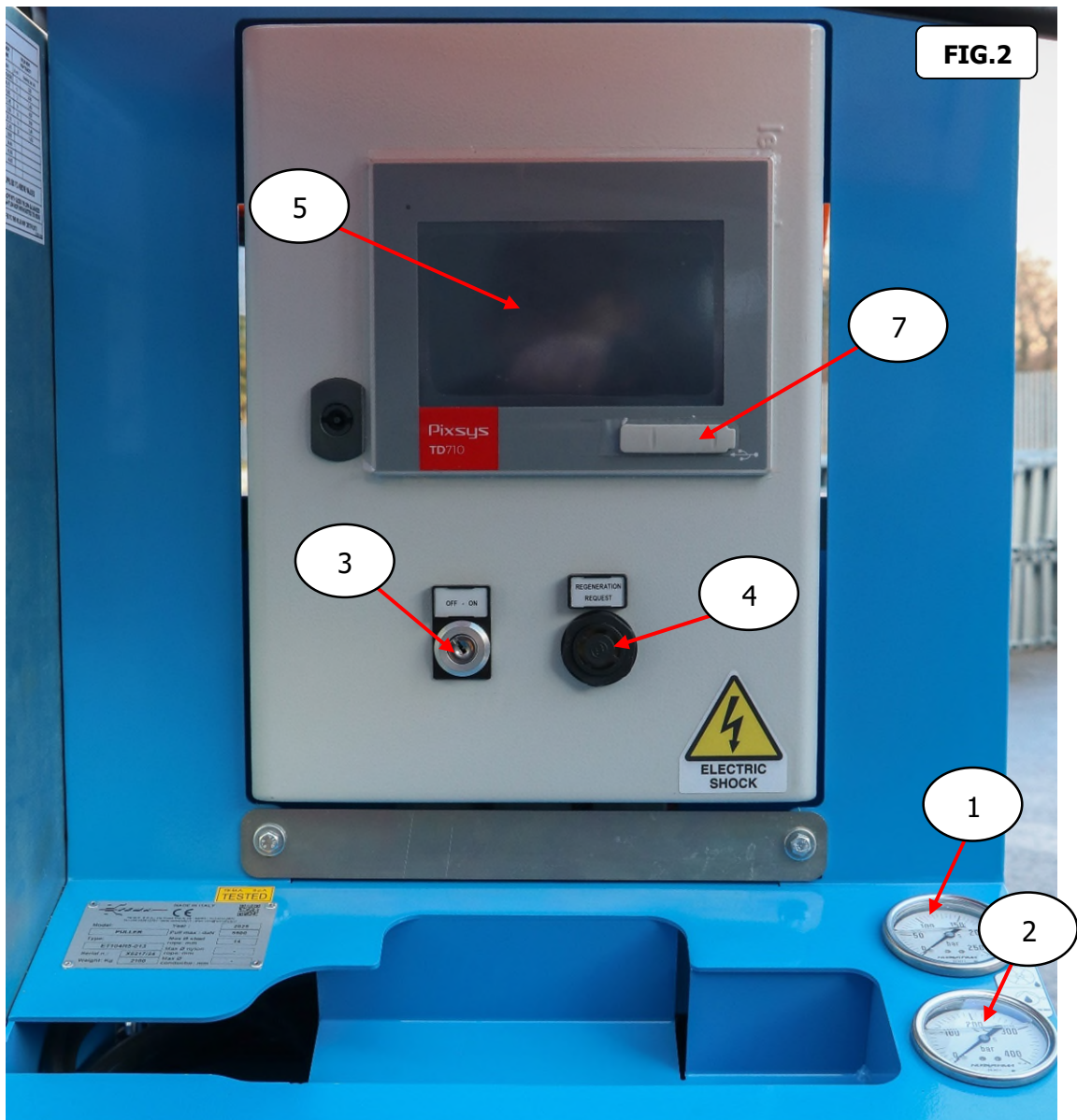

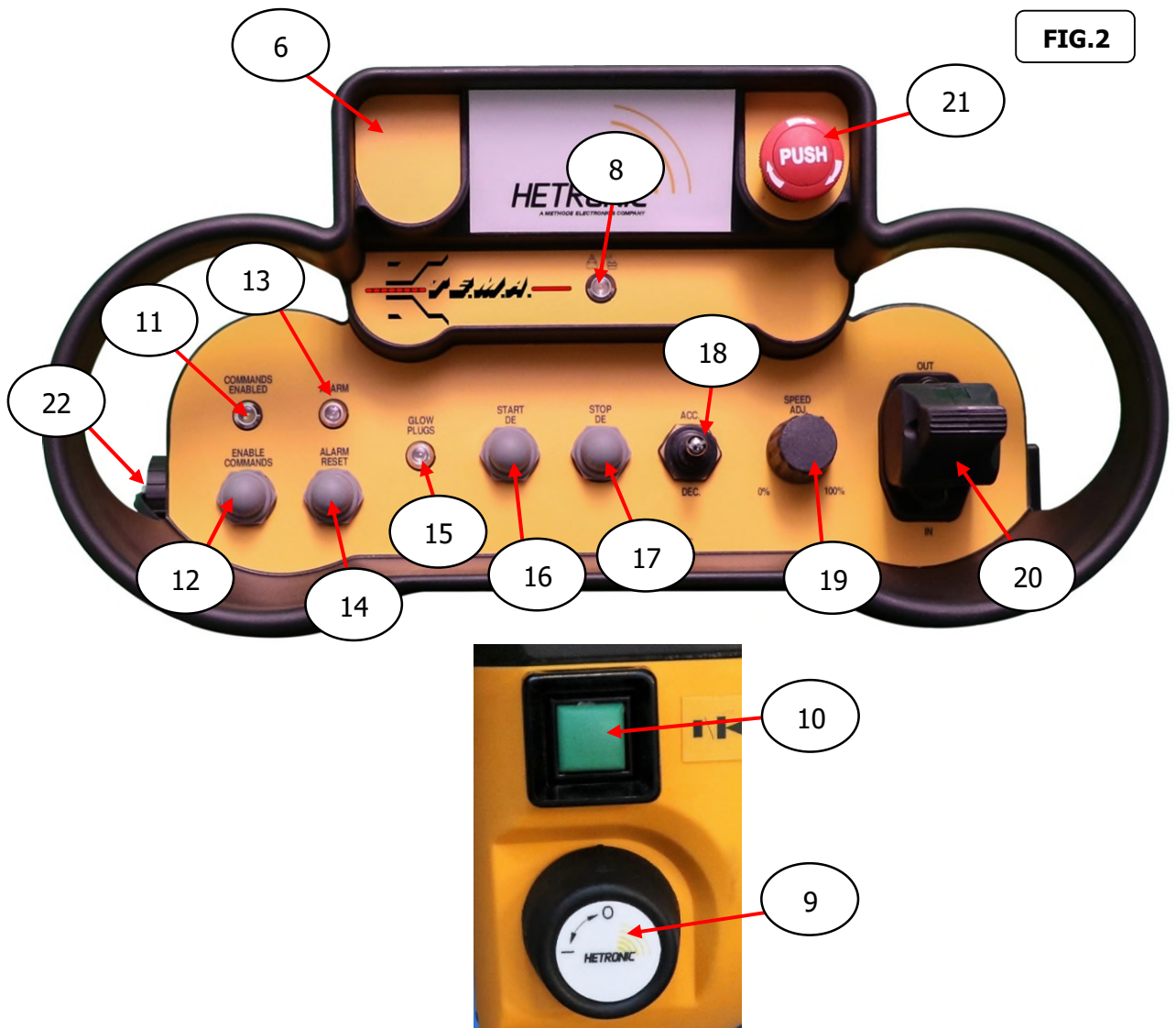

1	PRIMARY CIRCUIT PRESSURE GAUGE	12	"ENABLE COMMANDS" BUTTON
2	REWINDER CIRCUIT PRESSURE GAUGE	13	ACTIVE ALARM LIGHT (ORANGE)
3	CONTROL PANEL IGNITION KEY	14	ALARM RESET BUTTON
4	REGENERATION REQUEST	15	GLOW PLUG PRE-HEATING LIGHT (ORANGE)
5	HMI DISPLAY TOUCH SCREEN 7"	16	DIESEL ENGINE START BUTTON
6	REMOTE CONTROL	17	DIESEL ENGINE STOP BUTTON
7	USB PORT	18	DIESEL ENGINE REVS ACCELERATOR LEVER
8	LIGHT: ALARM (RED) / RUN (GREEN)	19	CAPSTAN SPEED LIMITER
9	REMOTE CONTROL ON SWITCH	20	SPEED ADJUSTMENT AND CAPSTAN ROTATION DIRECTION, PROPORTIONAL JOYSTICK
10	RADIO CONTROL ENABLING BUTTON	21	EMERGENCY BUTTON
11	CONTROLS ENABLED LIGHT (WHITE)	22	REMOTE CONTROL SOCKET CONNECTION



### 3.3 TRANSPORT

On top of the winch, 2 pad eyes are provided (fig.3A pos.1 e pos.2) in order to lift the machine considering the possible different configurations (with/without: fuel - hydraulic oil - rope). The winch can be lifted by using one single pad eye, that has a max capacity of 6614 lbs (3000 kg). The center of gravity position in the delivery configuration (rope installed, without hydraulic oil, without fuel) requires lifting from point 2, fig.3A.

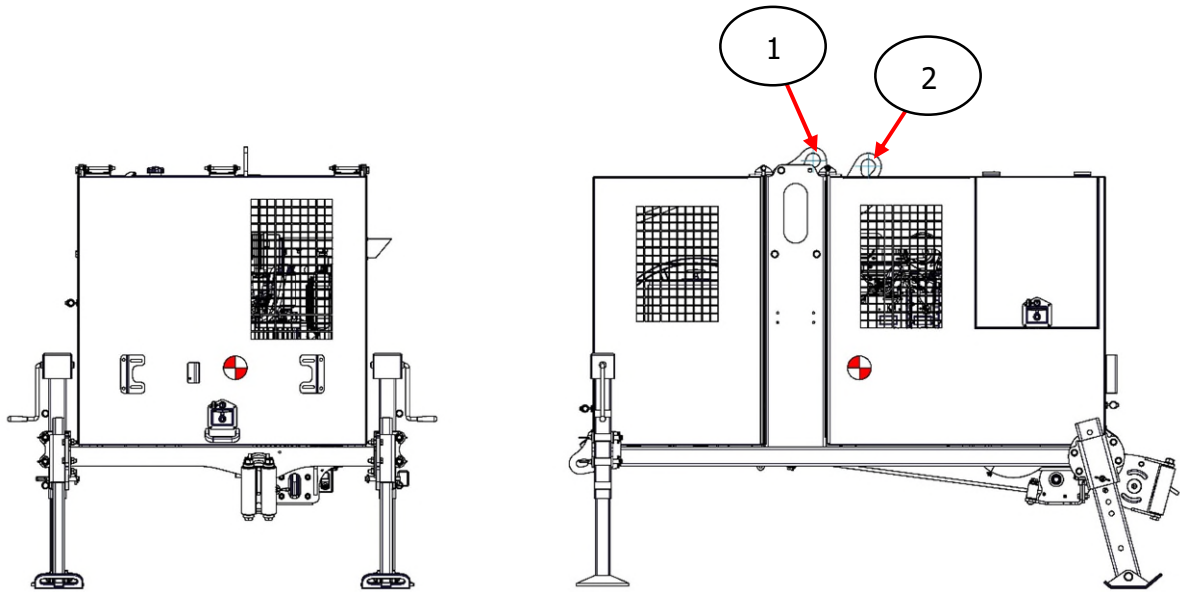

**FIG.3A**



### 3.4 MACHINE POSITIONING

Place the machine as much as possible aligned with the direction of the pull and then proceed as follows:

1. Lower the stabilizers (fig.3B pos.2) through the pin.
2. Anchor the machine to the ground using suitable ropes and tensioners, which give a total length of 10-16 feet (longer lengths are acceptable but can cause greater instability), connecting the special attachments (fig.3 pos.1) to the anchoring devices.

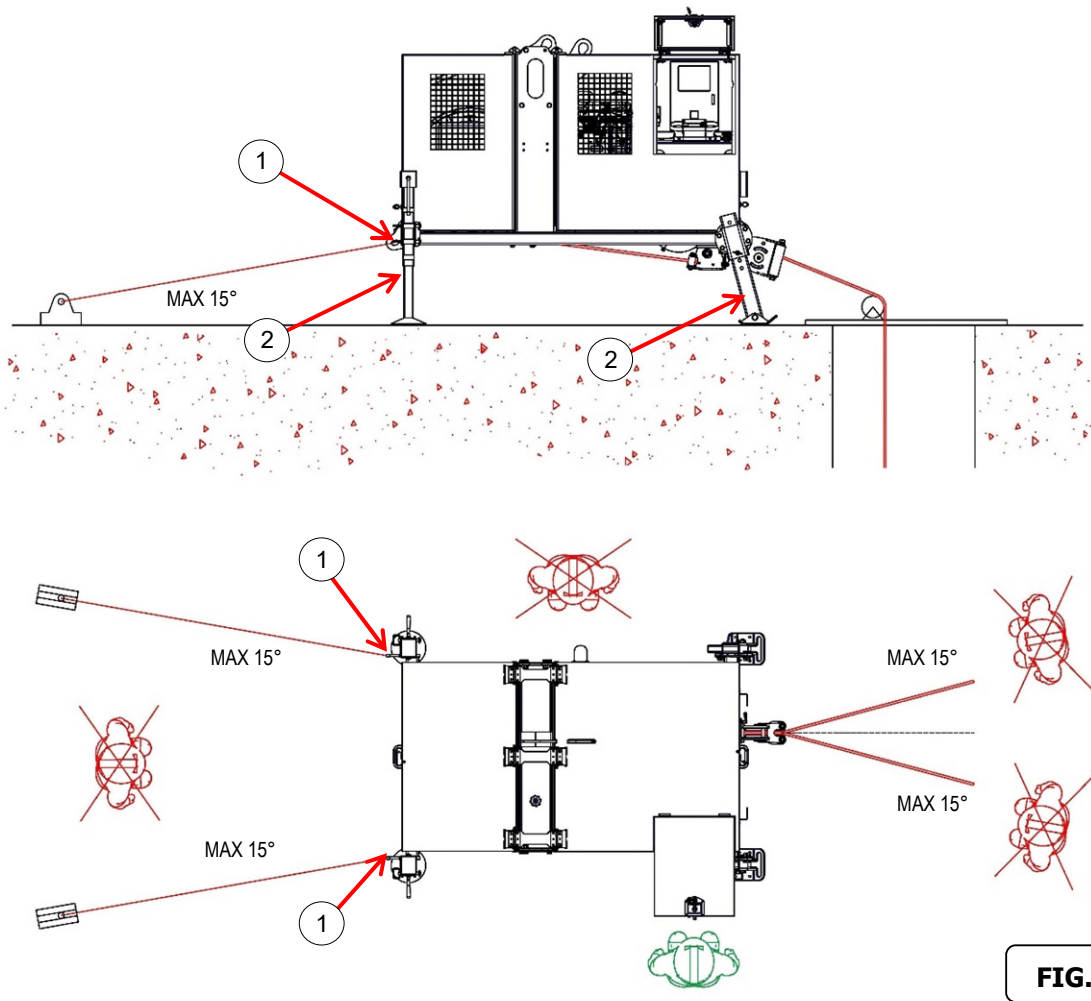

**FIG.3B**

#### **THE AREAS WHERE OPERATOR CAN STAY ARE THOSE INDICATED IN FIG.3B**

Before starting the installation phase, it is advisable to check the earth connections. Afterwards it is recommended to perform a pull test reaching the maximum load foreseen for the operations in progress, this for checking the anchorages and setting up the machine, as well as to check the exact functioning of the load cell. It is advisable to keep the rear anchors aligned as shown in the diagram (fig. 3B) so that the machine can settle freely. If you have any malfunctions or faults, do not proceed with the boring / laying operations, but contact the manufacturer.



Failure to comply with these requirements on anchoring can lead to situations of serious danger during use of the machine.



### 3.5 PREPARATION OF THE MACHINE FOR STRINGING

After placing the machine, act as follows:

1. Turn the ignition key (fig.2 pos.3) and wait for the HMI panel to turn on (fig.2 pos.5).
2. The operator / supervisor can set/modify parameters like max. speed, rope diameter, printing step, pulling threshold, through touch screen display.



**When the machine is started, recording starts automatically and a new work file is created with the starting time, so check that the correct WORKING DATA are entered before proceeding.**

**At each variation of the working data, a new work file is generated.**

3. Turn on the remote control, rotating the appropriate key from 0 to 1 (fig.2, pos.9) and pressing the green button (fig.2 pos.10), until both lights (fig.2 pos.11) (fig.2 pos.13) start to flash.
4. Press the alarms RESET button (fig.2 pos.14) to note the switching off of the alarm lights (fig.2 pos.13).
5. Press the "enable commands" button (fig.2 pos.12) to change the light from flashing to steady (fig.2 pos.11).
6. Press the "Start DE" button (fig.2 pos.16) to start the engine.



**If the system detects a steady environmental temperature, the glow plug pre-heating function automatically activates. The pre-heating lasts for 15 seconds and is noted by the activation of the orange light on the remote control (fig.2.pos.15). Having completed the pre-heating, the DIESEL engine will start automatically. If the engine does not start, wait at least one minute and repeat the process.**

**If, on the third attempt the engine does not start, and the display shows no alarm states:**



- Check the quality of the fuel in the tank and/or for any presence of dirt/impurities in the filter;
- Check that the emergency button has not been activated;
- Check that the end-stop devices (should there be any) are not closed.



**In case none of the listed problems be noted, contact TE.M.A. S.p.A. (Tel: (+39) 035-812781, E-mail: info@temaitaly.it)**

7. If the temperature is lower than 41°F, run the engine at idle for some minutes.
8. Adjust the diesel engine RPM using the accelerator (fig.2 pos.18), as needed.
9. Use the joystick (fig.2 pos.20) to pull/lay the rope. It is possible to limit the extension speed range using the potentiometer (fig.2 pos.19).
10. On reaching the threshold values (pull and/or speed), the machine sets the capstan winding speed to zero while holding the load under conditions of safety, inhibiting the joystick commands (fig.2, pos.20) in order to avoid further manoeuvres.
11. To restart work after having reached the thresholds (pull and/or speed), it is necessary to press the alarms reset button (fig.2 pos.14).



At the end of the working phase, retract the rope as far as possible inside the machine (see fig.B), avoiding entering the splicing inside the cabstans (fig.B pos.1). Then attach the spliced eye (fig.B pos.2) to the rear stabilizer and lock it.

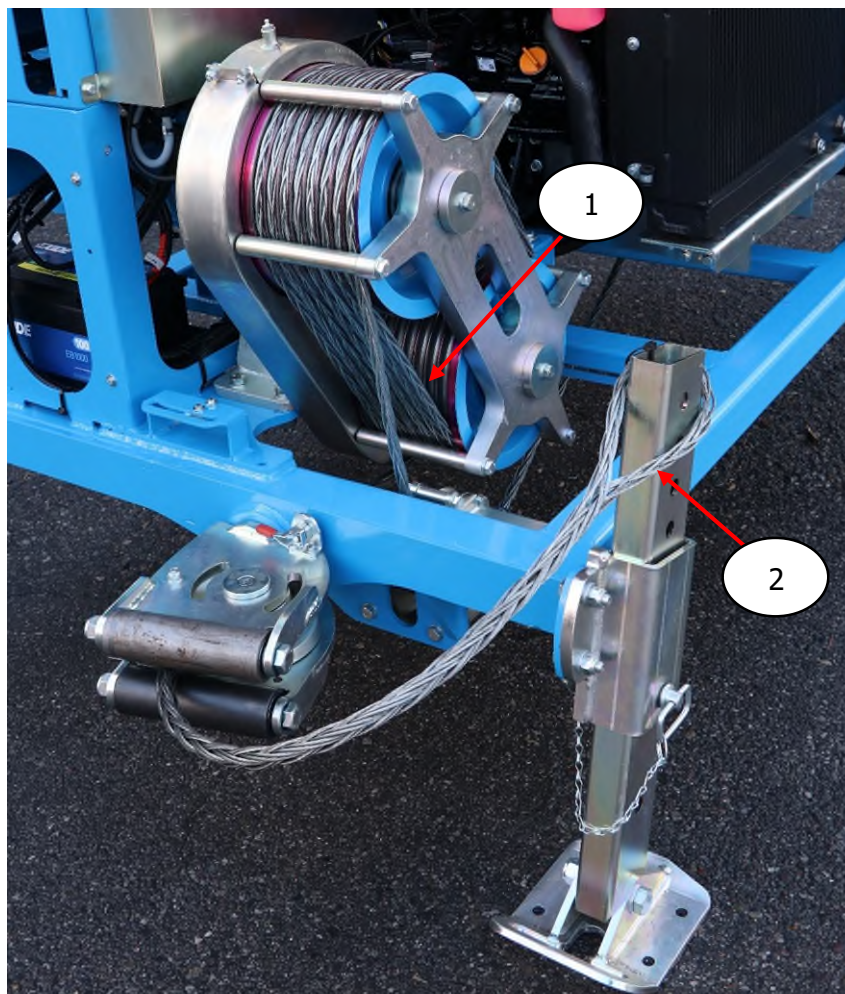

**FIG.B**



### 3.6 PERIODIC CHECK OF THE CABLE TENSION AT THE REWINDER

In order that the cable tension at the rewinder is optimal, the pressure related to the rewinder circuit (fig.2 pos.2) should be at around 507-1160 psi for steel cables, and 362-870 psi for nylon cables.

If necessary, this operation can be carried out by adjusting the control valve (fig.4 pos.1) and undertaking the following steps:

1. Unscrew the bolt (fig.4 pos.1).
2. Turn the nut (fig.4 pos.1) clockwise if an increase in tension is required, and anti-clockwise if a reduction is required.
3. Once the required tension is set, tighten the bolt and nut once more.

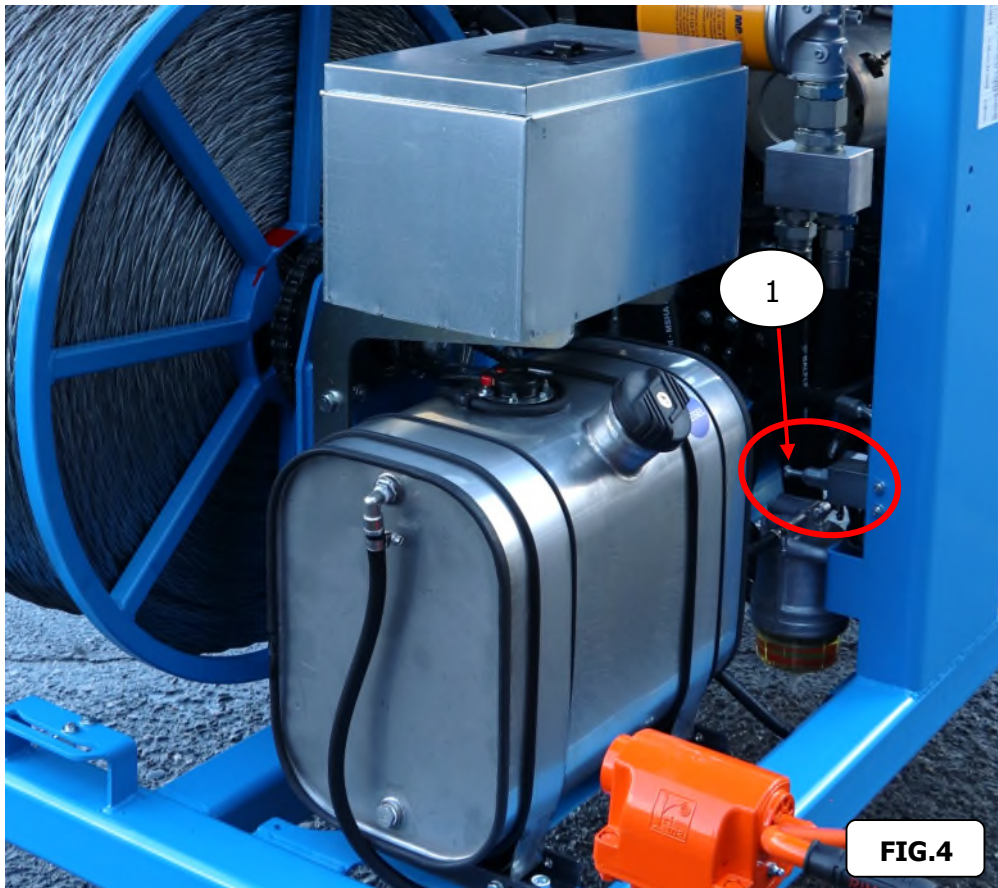

**In order to check and to obtain an optimum adjustment of the counter-pull during operation, it is advised to bring the drum to maximum capacity and to apply the maximum pull load. If the rewinder is set to a correct counter-pull, no cable sliding will be noted on the capstans.**

**If there's sliding, increase the pressure on the rewinder as in section 3.5.**

### 3.7 MACHINE STOP

To stop the machine, proceed as follows:

1. Carefully release the joystick (fig.2 pos.20).
2. Press the STOP DE button (fig.2 pos.17) to turn the engine off.
3. Turn the panel off by turning the key (fig.2 pos.3); also turn off the remote control with the key (fig.2 pos.9) and remove it if necessary.



### 3.8 ROPE WRAPPING

This operation is carried out implementing the following steps:

1. Open the front and rear bonnet (fig.5 pos.1) to access the capstans (fig.5 pos.3) and the reel (fig.5 pos.4).
2. Remove the anti-fleeting device (fig.5 pos.2).
3. Move proportional joystick to open negative brake, in this way the spooler can move and be aligned to the left of the reel to insert the rope into seat on the reel.
4. Install the rope (see fig. 5).
5. Re-install the anti-fleeting device (fig.5 pos.2).

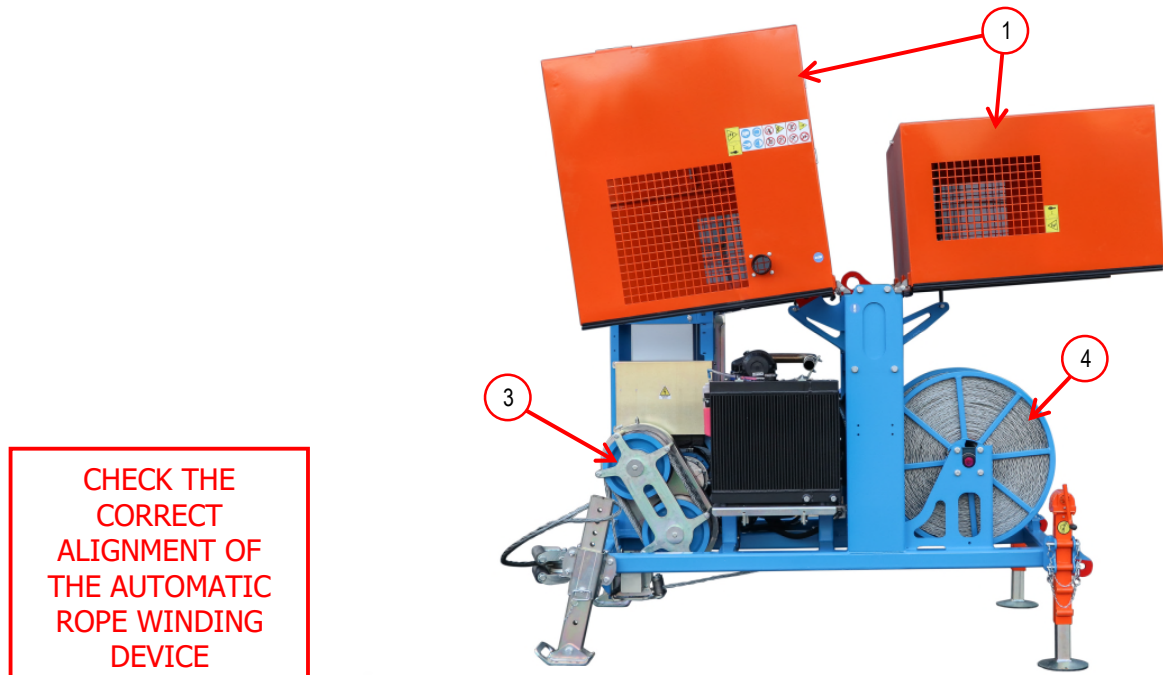

CHECK THE  
CORRECT  
ALIGNMENT OF  
THE AUTOMATIC  
ROPE WINDING  
DEVICE

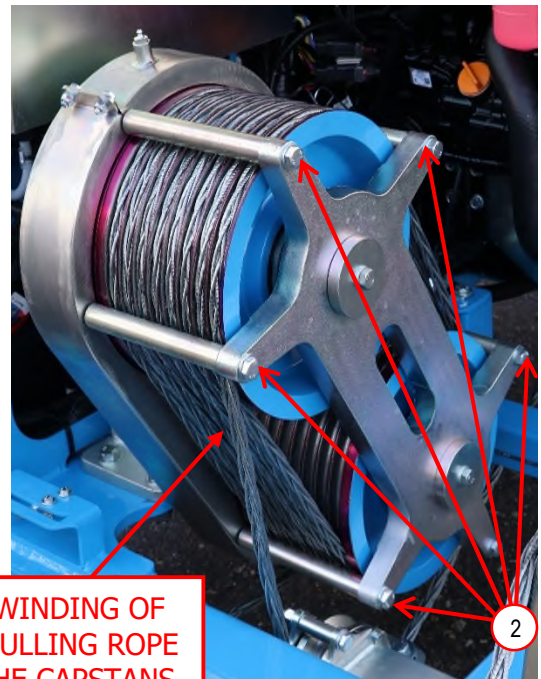
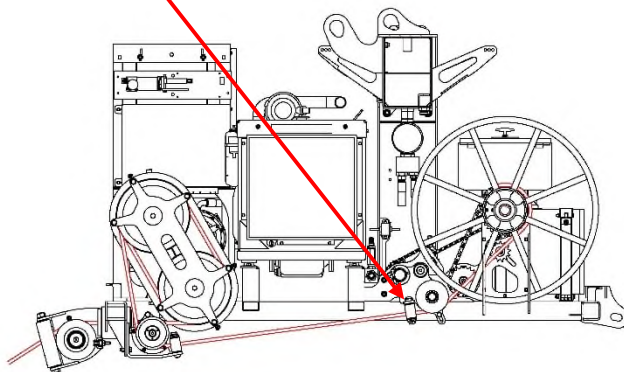

N°8 WINDING OF  
THE PULLING ROPE  
ON THE CAPSTANS  
GROOVES

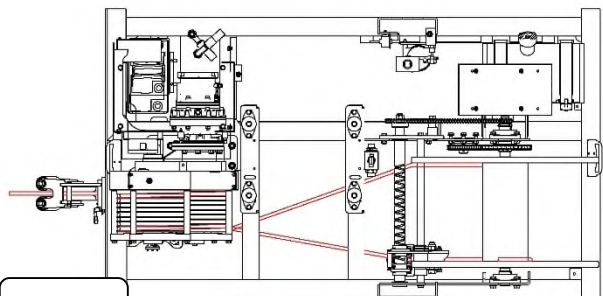

**FIG.5**



### 3.9 CABLE BLOCKAGE ON THE DRUM

1. Using the joystick control (fig. 2 pos.20) position the drum as in figure 6.
2. Turn off the machine (see § 3.7).
3. Unscrew the bolts (fig.6 pos.1) and insert the cable in the slot (fig.6 pos.2).
4. Re-tighten the bolts (fig.6 pos.1).



**Periodically check that the block (fig.6 pos.3) is well screwed in**

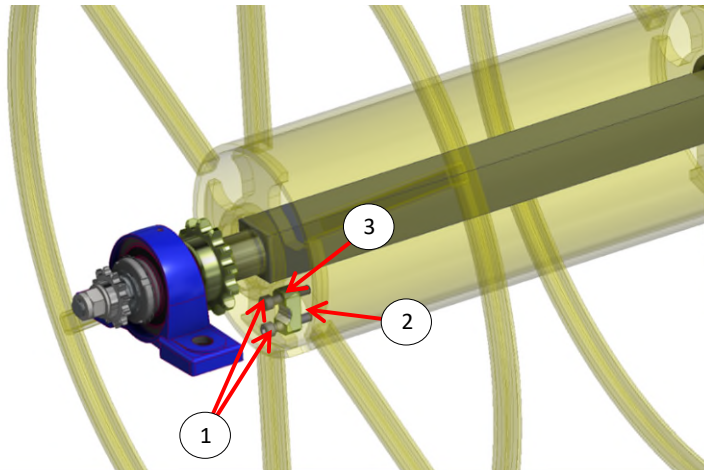

**FIG.6**

### 3.10 SAFETY DEVICES

The machine is equipped with the following safety devices:

1. A negative hydraulic brake which acts whenever the operator releases the control lever, or in the event of a fault in the hydraulic circuit.
2. Control over threshold pull and speed by HMI programming.
3. Sensors for detecting anomalies over the:
  - Fuel level
  - Engine oil pressure
  - Battery charger
  - Engine temperature
  - Engine speed



**It is strictly forbidden to use the machine without the protection covers, where established.**

### 3.11 EMERGENCY STOP BUTTON

The emergency stop function is activated with the stop button (fig.2 pos.21).



**Use the emergency stop button only for situations of danger to the operators**



**Use of this device for stopping the pull is prohibited.**



## 4. MAINTENANCE

### 4.1 GENERAL RULES

It is obligatory to interrupt the electrical power supply before carrying out any maintenance operation, with the exception of cases described in this manual. All maintenance operations on the machine must be carried out with the machine level and blocked.

### 4.2 ENDOTHERMIC MOTOR MAINTENANCE

For maintenance of the specific motor, refer to the attached manufacturer's user and maintenance manual.

### 4.3 HYDRAULIC CIRCUIT MAINTENANCE

Change the hydraulic oil and the filter cartridge (fig.7 pos.4) after the first 150 hours of work, then every 300 hours using one of the oils for the hydraulic circuit recommended in the attached oil and grease table.

To drain the used hydraulic oil:

1. Use the designated drain point located under the hydraulic oil tank (fig.7 pos.1).
2. Load the oil into the tank using the cap located in the upper part of the tank (fig.7 pos.2).
3. Periodically check the oil level in the tank (fig.7 pos.3) and, if necessary, top up with the same type of oil to the maximum level.



**Allow the hydraulic oil to cool completely before draining it off and use the appropriate personal protection equipment (gloves, apron, etc.).**

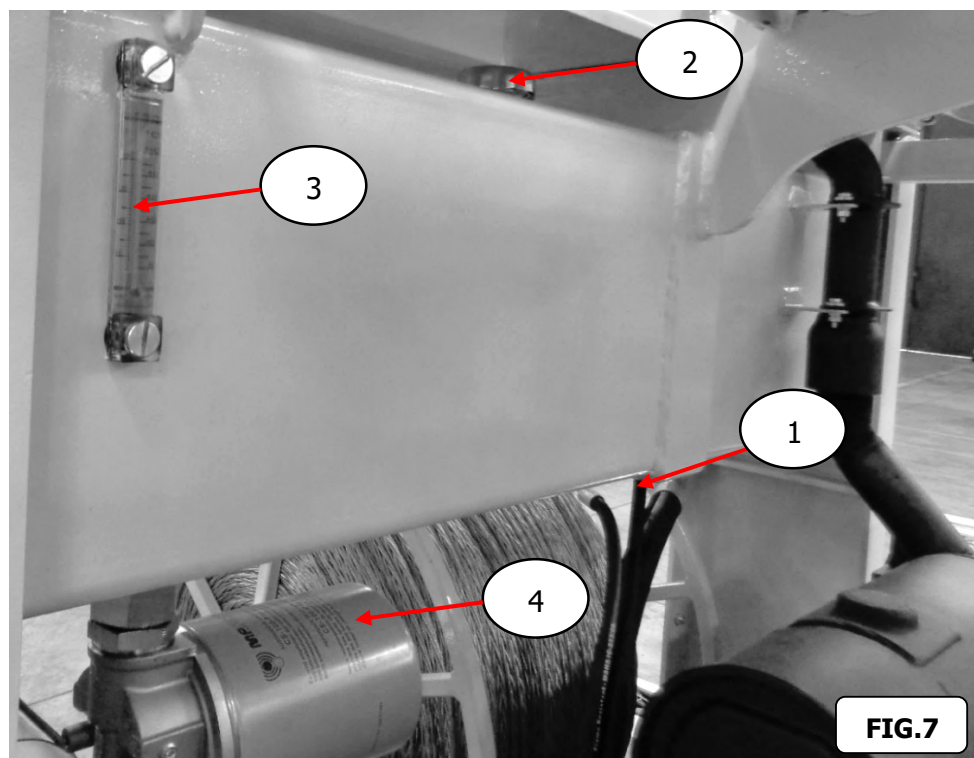



## 4.4 REGENERATION

### **Automatic regeneration (time required 30 minutes):**

- Automatic regeneration is performed every 100 working hours.
- When the warning light with the **smoke and temperature** symbol comes on, the engine is performing automatic regeneration, in this phase continue working without stopping the engine and if possible, increase the engine speed.
- When regeneration is complete and the light goes out, wait a few minutes before stopping the engine.

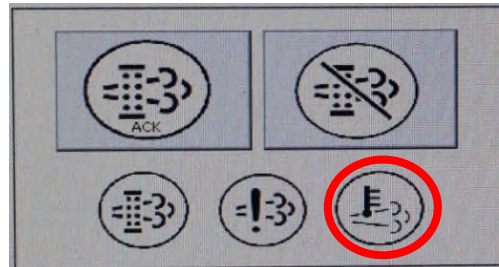

### **Regeneration request:**

If the engine fails to perform automatic regeneration for reasons of use, stationary regeneration is requested by steadily lighting up the PCD engine fault light and the regeneration request light (**filter and smoke**).

In this case it is necessary to inhibit the commands by pressing the "ENABLE CONSOLE" button on the console and the relative "COMMANDS ENABLE" light will start to flash.

The **ACK light** will also start flashing, at this point press the diesel synoptic button and press the ACK key for 3 seconds, in this way the stationary regeneration will start which will last about 30 minutes. The warning light with the **smoke and temperature** symbol will light on.

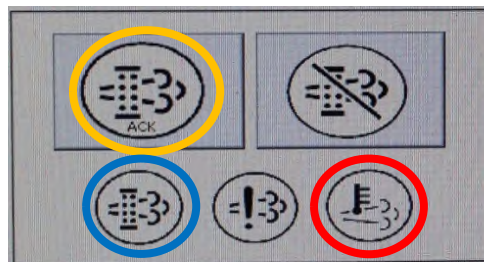

### **Stationary forced regeneration:**

- To start forced regeneration, the engine must have a temperature above 140° F.
- There must be no active alarms.
- Engine revolutions must be at a minimum.
- This regeneration can take place no earlier than 50 hours from the last active regeneration. However, if it is forced, the motor does not perform regeneration.
- To stop regeneration (NOT RECOMMENDED), press the crossed-out regeneration light, it lights up green and regeneration stops.



**Stationary regeneration not carried out:**

If stationary regeneration is not carried out, the engine goes into protection by limiting the revs. Service intervention is required to restore correct engine operation.

In the event of tampering or non-functioning of any component linked to engine emissions, the NCD and PCD warning lights will turn on with the relative error message, if these components are not repaired or restored the engine ECU after 36 hours of use will reduce the engine revs and power, after 64 hours of use the ECU will further reduce revs and power.

Once the component is reset the lights will go out and the engine will run normally.

**4.5 GREASING**

Greasing of chains, unwinder bolts and those points which, being external, do not benefit from forced lubrication.

Point of greasing:

- Coil bearing (fig.8 pos.1)
- Front stabilizer (fig.8 pos.2)

Periodically check the state of wear of the cable guide latch to ensure correct functioning of the unwinder. For this greasing action, use greases recommended in the attached oils and grease table.



**FIG.8**



**Greasing must be carried out with the machine turned off; that is with no parts in movement.**

**4.6 OTHER PERIODICAL OPERATIONS**

Checks on the engine transmission (chains, crown and pinion). In particular, the tensions of all the chains must be checked and, in case of loosening, use the appropriate chain tensioners to restore the optimal tension.

Checks on the hydraulic circuit (tubes, pumps, etc.). In particular, checks must be carried out for the absence of oil losses which might cause inefficiencies of the circuit.



#### 4.7 ORDINARY MAINTENANCE

The following table illustrates the maintenance programmes which the machine requires.

ELEMENT	QTY.	TYPE	PERIOD	PRODUCER
Hydraulic oil filter	1	CS-150-P10A	1st change 150 hours thereafter each 300 hours Or 1 year of downtime	MP FILTRI
Hydraulic oil	18 gal	ATF DEXRON II	1st change 150 hours thereafter each 300 hours Or 1 year of downtime	-
Winding screw	0.22 lbs	Spray grease for gears	As needed	ROL OIL
Chain	0.22 lbs	Spray grease for gears	As needed	ROL OIL
Capstan gears	0.66-1.1 lbs	Grease for gears	As needed	ROL OIL
Brake release oil	0.08 gal	ATF DEXRON II	1st change 150 hours thereafter each 300 hours Or 1 year of downtime	-
Diesel engine oil	See engine handbook	DOLOMITI 15/W40	1st change 150 hours thereafter each 300 hours Or 1 year of downtime	ROL OIL

If the manufacturer's oil indicated in the table is not available, consult the attached table of comparative oils.

Compile the attached maintenance record form for all maintenance carried out.

In the event of disputes (due to machine malfunctions) the above-mentioned form must be presented to TE.M.A. S.p.A. so that the causes of the malfunction may better be interpreted.



**ATTENTION:**



**TE.M.A. S.p.A. declines all responsibility for damage to property and/or persons caused by insufficient maintenance.**



## 5. DESCRIPTION "HMI" MACHINE MANAGEMENT

### 5.1 "HMI" MACHINE RECORDING AND MANAGEMENT SYSTEM

The machine is designed to work with the integrated electronic system "HMI".

In "supervisor mode" it is possible, through the insertion of a password, to insert the fundamental working settings and to extract during the same work a log file in pdf extension.

The intuitive display with touch screen technology and 7" screen size, allows you to set the desired work data from the operator in the field. Through the menus of the same display, it is possible to manage the recording files of the work done, exploiting the use of an internal storage memory that cannot be modified.

The internal memory from 1 GB, allows the saving of approximately 200.000 lines of data acquisition, correspondent to approximately 620 miles of stringing with an acquisition step of 16 feet. In spite of the high capacity of the internal memory, at least once a year it is advisable to back up the memory and delete it.

To empty the memory, it is sufficient to press the button "CLEAR ENTIRE FOLDER" as explained on FILE MANAGER page of this manual, this operation is executable only under password supervisor.

The working files in pdf format, are stored by date of registration in a folder in the memory not editable, you can export them and are viewable on any PC with general reader of pdf files.

**WARNING:** At the start of the machine the registration starts automatically and a new working file is created with the start time, then check that the correct WORKING DATA are inserted before proceeding.

Each change in working data generates a new work file.

The HMI system is prepared for the extrapolation of the various work files, drawing from the internal memory not editable from the menu "file management". At the end of the operation turn off the machine to complete the saving of the file, then turn on the machine again, insert the USB key in the port and proceed with saving the files with a common USB stick.

**WARNING:** To export the data you need to insert a USB key with storage space of at least 1 GB before pressing the "COPY FULL FOLDER" button.

Below is an example of displaying the exported folder and files on USB key:

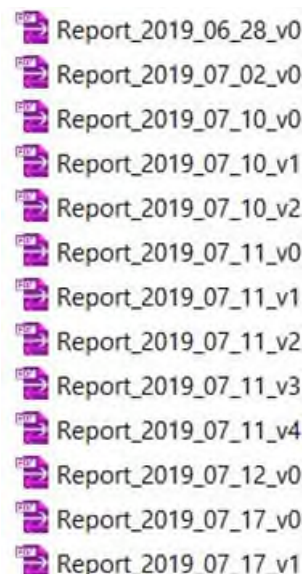
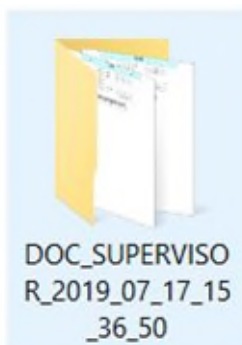



These exported PDF files (not editable) illustrate the working conditions carried out and also show the intervention of the alarms for exceeding the threshold, if some of them have been verified. Here is an example of a file:

**H** **REPORT** **LL**

<i>Nome Operatore</i>	BB	<i>Matricola</i>	22
<i>Luogo</i>	AA	<i>Modello</i>	11
<i>Tipo di Cavo</i>	CC		
<i>Massimo Tiro [ daN ]</i>	5500		
<i>Massima Velocità [ m/min ]</i>	55	<i>MT TOT [m]:</i>	188
<i>Temperatura ambiente [°C]</i>	26	<i>Stop</i>	2019-07-11 14:49:6

L [m]	F [daN]	S [m/min]	F Alm	S Alm
8	1011	20		
18	988	19		
28	2508	16		
38	2488	16		
48	2488	16		
58	2457	16		
68	2460	15		
78	2459	16		
88	2465	16		
98	2414	15		
108	2449	15		
118	2459	15		
128	2725	27		
130	2516	31		
140	2614	32		
150	2602	32		
160	2587	30		
178	2668	32		
188	2576	31		
198	2576	32		
208	2589	31		
218	2560	31		
228	2542	32		
238	2539	32		
248	2595	30		
238	1343	-38		
228	1569	-37		
218	1397	-40		
208	1378	-41		
198	1398	-40		
188	1432	-40		
178	0	-9		



## 5.2 PASSWORD

The HMI system has 2 different access categories with which you can access and change your work settings.

The two categories are divided as follows:

- **Operator shall:**

Have access to the basic working settings in the "PROCESSING DATA" section:

- Place
- Name of operator
- Type of cable
- Maximum shooting work
- Maximum working speed

- **Supervisor shall:**

By entering the dedicated password, you have access to advanced settings for machine control such as:

- Step saving data
- Saving overspeed-overload alarms
- Data processing supervisor
- Management of files
- Power limitation system

**Operator:**

No password

**Supervisor:**

User name: super

Password: super



### 5.3 RADIO CONTROL DESCRIPTION

The following illustration shows the radio control layout.

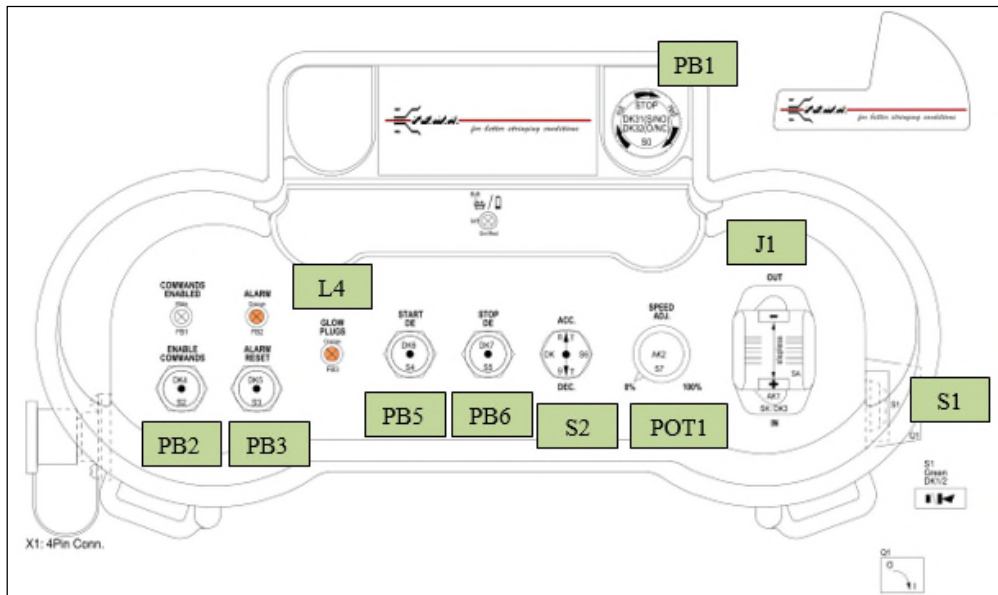

#### S1 – Enabling Radio control

To enable the radio control unit after each switching on and after having released the emergency mushroom button, it is necessary to rotate the S1 control and press the corresponding button.

#### PB1 – Emergency button

On pressing the emergency mushroom button, the diesel engine is turned off and all the valves and electro-valves are deexcited. The brake control valve is not managed by the emergency circuit.

#### PB2 – “Enable Commands” button and “Commands Enabled” light

The PB2 button allows for switching on the diesel control panel and for enabling the winch commands.

The L2 light is interpreted as follows:

- Steady light: console enabled
- light out: Console disabled

Note: The console cannot be activated in the event of an active emergency or if the wired control is not communicating with the switchboard.

#### PB3 – “ALARM RESET” button “Alarm” light

The PB3 button allows for resetting the active alarms as long as the conditions which generated the alarm are no longer present.

The L3 light is interpreted as follows:

- Flashing: Trips presence;
- steady light: Warning presence;
- light out: No trip and no warning presence;



#### **L4 – “Glow Plugs” light**

The L4 light is interpreted as follows:

- Steady light: Glow plugs on;
- light out: Glow plugs off;

#### **PB5 – “START DE” button**

The PB5 button allows for turning on the diesel engine in the event that there are no overriding alarms.

It is not necessary to keep the button pressed in order to complete the diesel engine switch on.

#### **PB6 – “STOP DE” button**

The PB6 button allows for turning the diesel engine off.

#### **S2 – “ACC/DEC” selector**

The S2 selector allows for altering the revolutions of the diesel engine once start-up has been completed.

The control system automatically brings the engine revolutions to minimum each time the engine is switched off.

#### **POT1 – “Speed ADJ” potentiometer**

The "Speed ADJ" potentiometer allows for adjusting the maximum ratio of the joystick speed, allowing for adjusting the machine speed with greater precision according to the operator's requirements.

#### **J1 – “IN/OUT” Joystick**

Once the console is enabled and the diesel engine is switched on, as long as there are no overriding alarms, the operator can recover or pay out cable by using the joystick J1 as required operationally.



## 6. HMI DESCRIPTION

The machine is equipped with a 7" display.  
This chapter contains a description of the operator interface pages.

### 6.1 MAIN PAGE

The "MAIN" page contains the main information, useful for monitoring the machine status during operation.

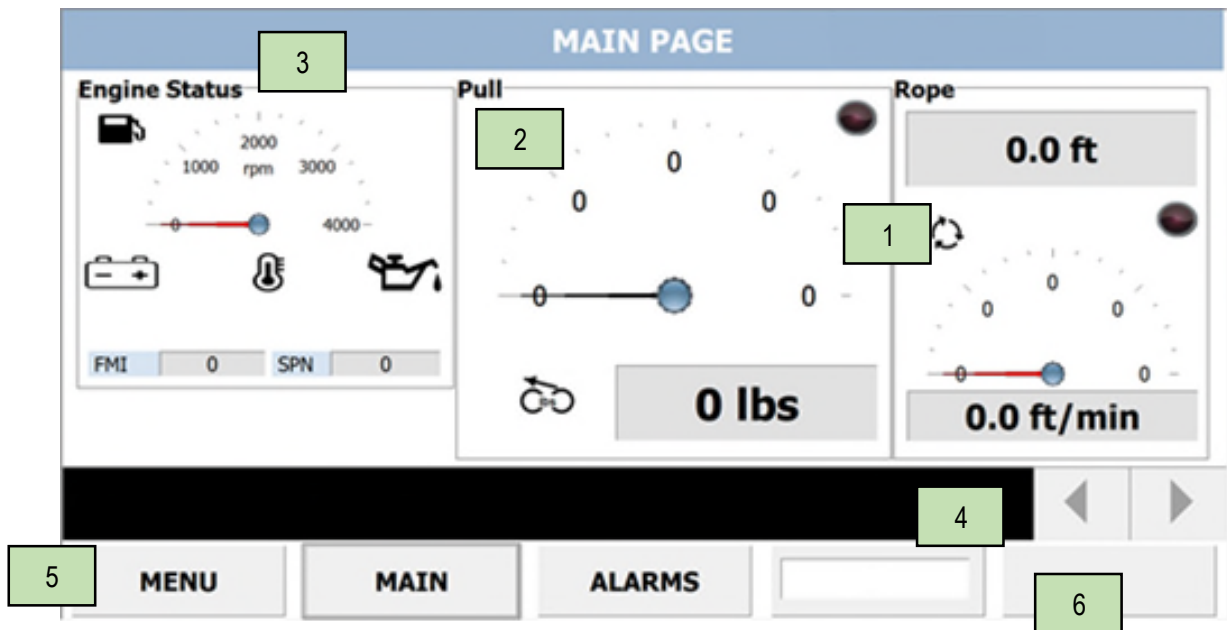

CODE	DESCRIPTION
1	This section provides the following information: - ROPE: number of rope/conductor meters wound/unwind last reset. - SPEED: current rope speed
2	This section provides information about the current pulling force
3	This section contains the main information related to the diesel engine. The red lights illuminate if the following conditions are verified: - Low fuel level - low oil pressure - battery not charging - high engine temperature - engine overspeed
4	This section contains the last active alarm and allows for browsing the active alarms
5	This section allows for accessing the pages indicated by the titles on the buttons
6	This section contains the name of the connected user



## 6.2 MENU

The "MENU" page allows for access to the control panel page by pressing the corresponding button. All those pages which can be recalled from the menu are visible to the operator.

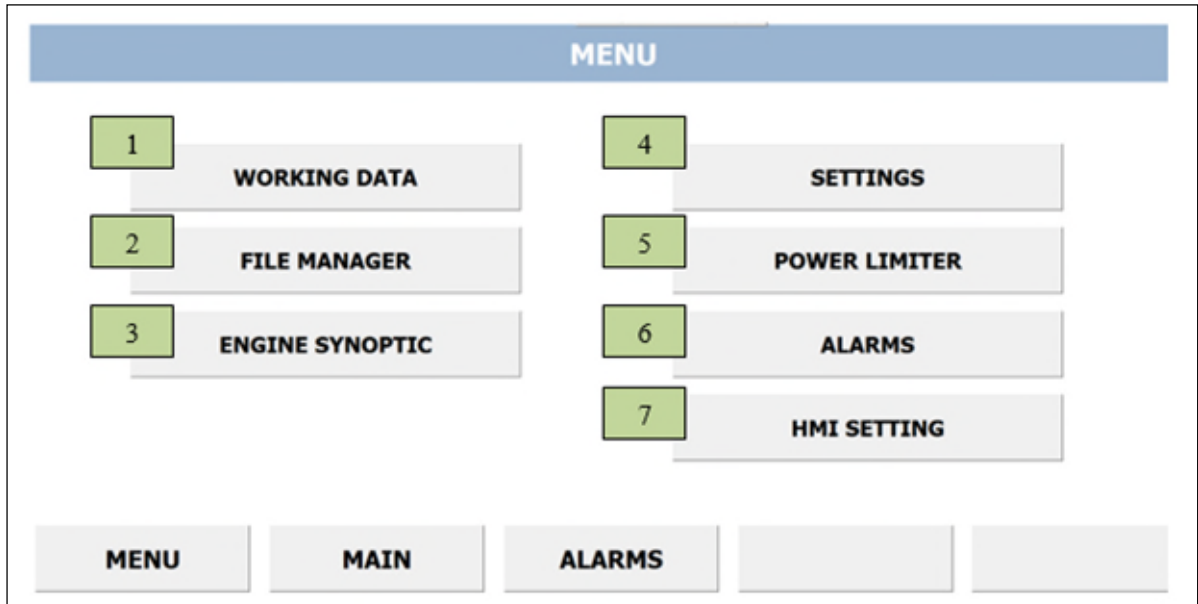



### 6.3 WORKING DATA

The following illustration shows the page dedicated to processing.

CODE	DESCRIPTION
1	This section allows to set the data for the current operation, which will be saved in the work report. All data can be modified by the operator, except for the save step which is protected by the supervisor's password.
2	This section displays the metres of cable wound on from the last reset. Pressing the "Reset rope feet" button the counter goes to zero This function is not password protected.
3	By pressing this button, which is protected by the supervisor's password, it is possible to activate or deactivate the saving of data related to the overspeed or overload alarms.
4	This banner indicates to the operator that data saving is active.
5	By pressing this button, which is protected by the supervisor's password, it is possible to activate a printout of the last report.
6	By pressing this button, which is protected by the supervisor's password, it is possible to access the page dedicated to the setting of the supervisor's parameters.
7	This section allows for accessing the pages indicated by the titles on the buttons



## 6.4 SUPERVISOR WORKING DATA

The following illustration shows the page dedicated to the setting of the supervisor's parameters.

CODE	DESCRIPTION
1	This section allows for setting the save step of the samples during operation.
2	This section shows the currently set value in inches of the diameter of the conductor.
3	This section shows the value in inches of the diameter of the conductor whose setting is required.
4	By pressing this button, it is possible to set the new conductor diameter value.
5	Pressing the "Reset rope feet" button the counter goes to zero
6	By pressing this button, which is protected by the supervisor's password, it is possible to activate or deactivate the saving of data related to the overspeed or overload alarms.
7	This banner indicates to the operator that data saving is active.
8	By pressing this button, it is possible to activate a printout of the last report.
9	This section allows for accessing the pages indicated by the titles on the buttons



## 6.5 FILE MANAGER

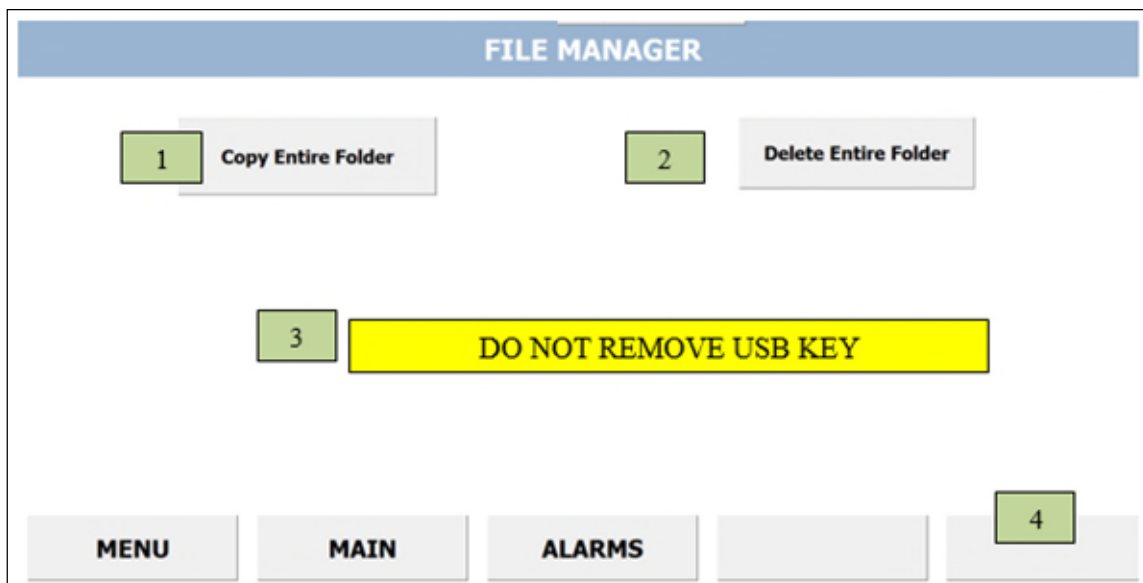

CODE	DESCRIPTION
1	By pressing this button, it is possible to copy the whole folder relating to the files saved onto a USB device. Regular saving of the work file is advised.
2	By pressing this button, which is protected by the supervisor's password, it is possible to cancel the folder containing the saved files.
3	This message appears while files are being saved on the USB device.
4	This section allows for accessing the pages indicated by the titles on the buttons



## 6.6 DIESEL ENGINE SYNOPTIC

The following page contains the status of the diesel engine.

### ENGINE SYNOPTIC

**Engine Status**

1

**Dashboard**

2

**Information**

Hour Counter	0	Reset
Rev Counter	0	
Battery Volt [V]	0.00	3
Ambient Temperature [°F]	0.00	
Engine Temperature [°F]	0	4
Engine Pressure [psi]	0	
Engine Consumption [GPM]	0.000	
FMI	0	SPN
		0

5  
**MENU**

**MAIN**

**ALARMS**

CODE	DESCRIPTION
<b>1</b>	This section contains the following information related to the diesel engine: - STATUS SWITCHED ON (green background)/OFF (white background) - POWER LIMITER: Red light lit if the limiter power is active
<b>2</b>	This section contains the main information related to the diesel engine: The red lights illuminate if the following conditions are verified: - Low fuel level - low oil pressure - battery not charging - high engine temperature - engine overspeed
<b>3</b>	This section contains the following information: - diesel engine operating hours with "Reset" button protected by the supervisor's password - diesel engine RPM - current battery voltage
<b>4</b>	This section contains the noted environmental temperature value.
<b>5</b>	This section allows for accessing the pages indicated by the titles on the buttons.



## 6.7 POWER LIMITER

The following page shows the page dedicated to the settings related to the power limiter. This function limits the maximum speed of the cable on the basis of the actual number of revolutions of the diesel engine and the current pull on the cable in order to avoid the engine cutting out.

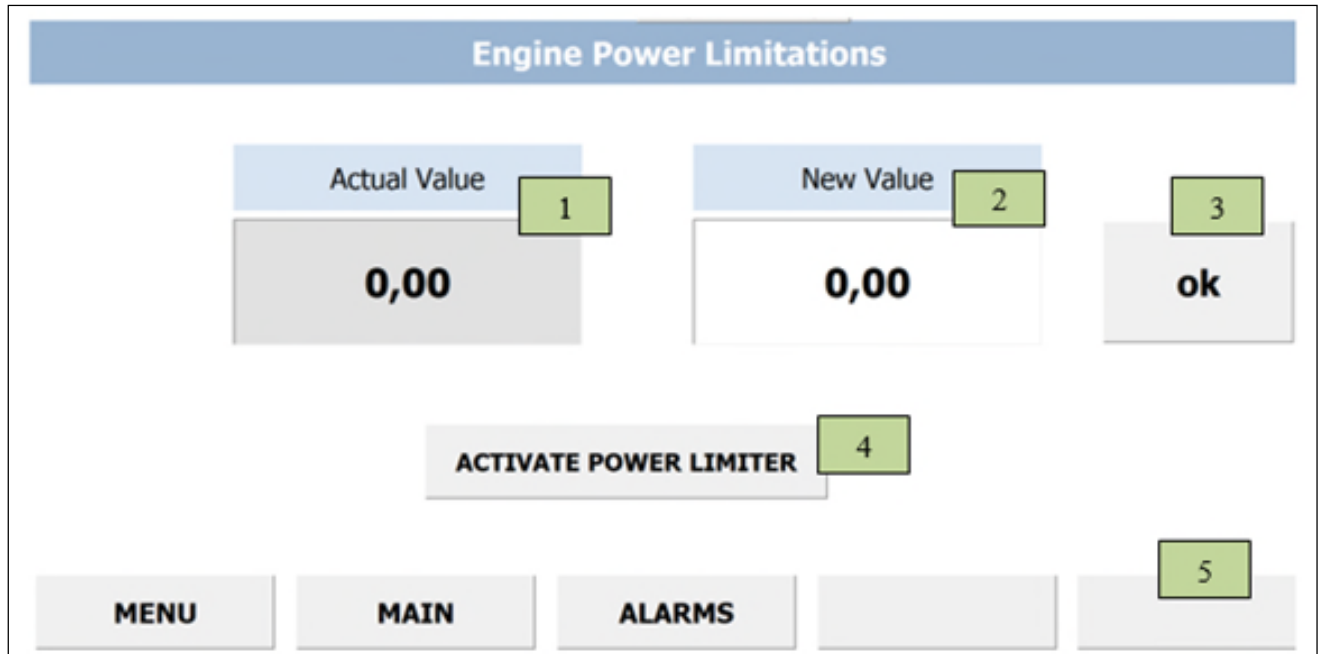

CODE	DESCRIPTION
1	This section shows the value in KW in relation to the maximum power currently set to the drive.
2	This section shows the value in KW in relation to the power to the drive required to be set.
3	By pressing this button which is protected by the manufacturer's password, it is possible to set the new power value.
4	This button, which is not password protected, allows for the activation or deactivation of the "power limiting" function.
5	This section allows for accessing the pages indicated by the titles on the buttons



## 6.8 ALARMS

The following two pages dedicated to monitoring of alarms are available:

- Active alarms
- historical alarms

These pages are shown in the following illustrations.

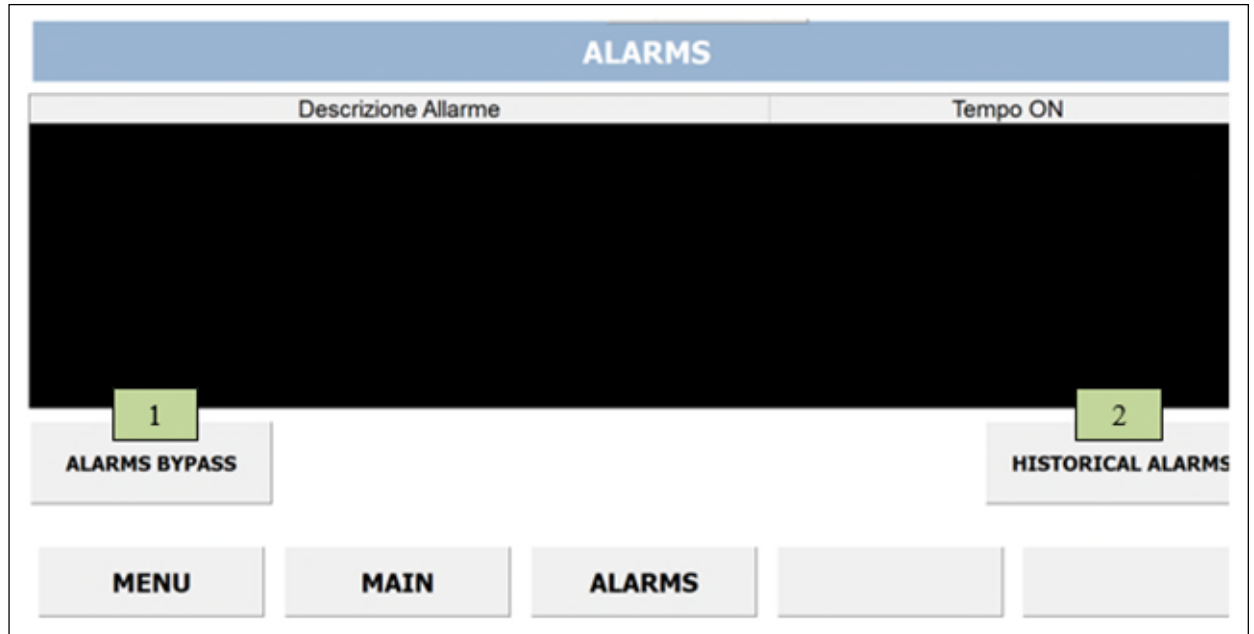

CODE	DESCRIPTION
1	This button, which is protected by the supervisor's password, allows for activating the ALARMS BYPASS. If this function is active, no alarm will override except for an emergency.
2	Pressing this button activates the alarms history page.

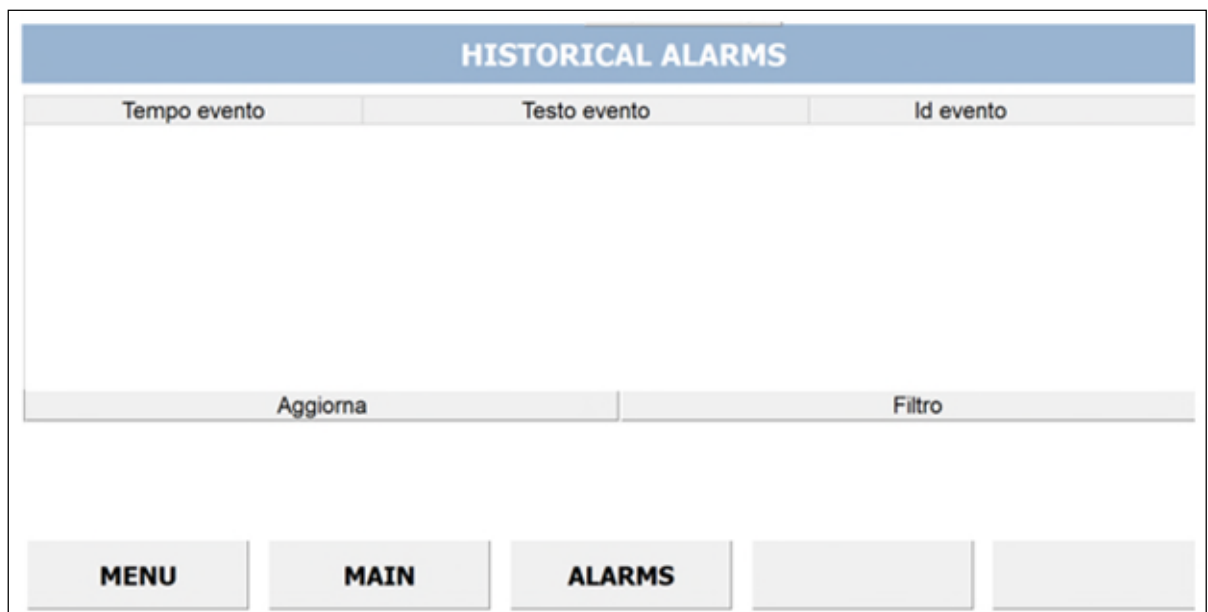



## 6.9 HMI SETTINGS

The following page allows for modifying the general machine settings.

System Settings

Date and Time

Year	Month	Day	Hours	Minutes	Seconds	
2024	5	14	14	25	0	<b>SET SYSTEM TIME</b>
0	0	0	0	0	0	

Stop Runtime

User Log Off 2

Machine Type 3

Model ET104R5-S07

ID Number 4

Field 1

Field 2

USA

5

MENU

MAIN

ALARMS

6

CODE	DESCRIPTION
<b>1</b>	This section allows for setting the date and time on the operator panel. The confirmation button is protected by the supervisor's password.
<b>2</b>	This button, which is protected by the manufacturer's password, allows for closing the programme. Only used for maintenance activities.
<b>3</b>	By pressing this button, the connected user can immediately disconnect him/herself. Access to the protected functions, requires the re-insertion of the password.
<b>4</b>	This section, which is protected by the manufacturer's password, allows for inserting MODEL, SERIAL NUMBER and CLIENT for the printout of data on the report.
<b>5</b>	Pressing on the flag activates the language of the corresponding state.
<b>6</b>	This section allows for accessing the pages indicated by the titles on the buttons



## **7. ATTACHED DOCUMENTS**

- Comparative table of recommended oils, grease and endothermic engine oils
- Ordinary and Extraordinary maintenance table
- Endothermic motor maintenance manual





