

Wagner Smith



Equipment Co.

OPERATOR'S MANUAL

MODEL T-3BWT-10-72H-FT4
HYDROSTATIC BULLWHEEL TENSIONER
CONTROL # _____
SERIAL # _____



Wagner-Smith Equipment Co.
5701 Highpoint Parkway
Burleson, TX 76028
USA

(800) 666-6567
(817) 447-8085
Fax: (817) 447-8917
E-mail: info@wagnersmith.com
Web page: <https://wagnersmith.com>

OPERATOR'S MANUAL INDEX

SECTION	DESCRIPTION
A	HAZARD WARNING
B	INTRODUCTION
C	SPECIFICATIONS
D	DESCRIPTION OF INDIVIDUAL FUNCTIONS
E	OPERATIONS
F	ROUTINE MAINTENANCE
J	JOHN DEERE ENGINE MAINTENANCE

SECTION "A"

SAFETY

ATTENTION:

This manual is intended to give operational, parts, and maintenance information for the unit referenced on the front cover. It is not intended to replace safe operating practice or serve as a tension/ stringing operation procedures manual. This piece of equipment is designed for use in tension/ stringing operations within its specification only. Any use other than this that is not authorized by Wagner-Smith Equipment Co. is potentially dangerous and could result in severe injury or death. Additionally, this equipment should only be operated by trained personnel who are fully aware of the proper operating procedures and potential safety hazards encountered during tension/ stringing operations.

FIG	DESCRIPTION	PAGE #
	SAFETY	A-2...5
	WARNINGS	A-5...6

SECTION “A” SAFETY

<p>RECOGNIZE SAFETY INFORMATION</p> <p>This is the safety-alert symbol. When you see this symbol on your machine or in this manual, be alert to the potential for personal injury.</p> <p>Follow recommended precautions and safe operating practices.</p>	
<p>“DANGER” – Is used to indicate a hazardous situation which has a high probability of death or severe injury. Danger should not be considered for property damage accidents unless personal injury risk is present.</p>	
<p>“WARNING” – Is used to indicate a hazardous situation which has some probability of death or serious injury. Warning should not be considered for property damage accidents unless personal injury risk is present.</p>	
<p>“CAUTION” – Is used to indicate a hazardous situation which may result in minor or moderate injury. However, caution should not be used when there is a possibility of death or serious injury. Caution should not be considered for property damage accidents unless personal injury risk is present.</p>	
<p>FOLLOW SAFETY INSTRUCTIONS</p> <p>Carefully read all safety messages in this manual and on your machine safety signs. Keep safety signs in good condition. Replace missing or damaged safety signs.</p> <p>Learn how to operate the machine and how to use controls properly. Do not let anyone operate without instruction.</p> <p>Keep your machine in proper working condition. Unauthorized modifications to the machine may impair the function and/or safety and affect machine life.</p> <p>If you do not understand any part of this manual and need assistance, contact Wagner-Smith Equipment Company.</p>	

SECTION “A” SAFETY

PREPARE FOR EMERGENCIES

Be prepared if a fire or accident occurs. Keep a first aid kit and fire extinguisher handy. Keep emergency numbers for doctors, ambulance service, hospital, and fire department near your telephone.



PROTECT AGAINST NOISE

Prolonged exposure to loud noise can cause impairment or loss of hearing.

Wear a suitable hearing protective device such as earmuffs or earplugs to protect against uncomfortable loud noises.



STAY CLEAR OF ROTATING SPINDLES AND CHAIN DRIVES

Entanglement in rotating reel spindle and reel spindle drive can cause serious injury or death.

Keep all guards in place at all times.

Wear close fitting clothing. Stop the engine and be sure the drives are completely stopped before performing any type of service on the equipment.



PRACTICE SAFE MAINTENANCE

Understand service procedure before doing work. Keep area clean and dry. Never lubricate, service, or adjust machine while it is moving. Keep hands, feet, and clothing from power driven parts. Disengage all power and operate controls to relieve pressure. Stop the engine. Remove the key. Allow machine to cool.

Keep all parts in good condition and properly installed. Fix damage immediately. Replace worn or broken parts. Remove all buildup of grease, oil, or debris.

Disconnect battery ground cable (-) before making adjustments on electrical systems or welding on machine.



SECTION "A" SAFETY

AVOID HIGH-PRESSURE FLUIDS

Escaping fluid under pressure can penetrate the skin causing serious injury.

Avoid the hazard by relieving pressure before disconnecting hydraulic or other lines. Tighten all connections before applying pressure.

Protect hands and body from high pressure fluids.

If an accident occurs, see a doctor immediately.



REMOVE PAINT BEFORE WELDING OR HEATING

Avoid potentially toxic fumes and dust.

Hazardous fumes can be generated when paint is heated by welding, soldering, or using a torch.

Do all work in a well-ventilated area. Dispose of paint and solvent properly.

Remove paint before welding or heating:

- If you use sand or grind paint, avoid breathing the dust. Wear an approved respirator.
- If you use solvent or paint stripper, remove stripper with soap and water before welding. Remove solvent or paint stripper container and other flammable material from area. Allow fumes to disperse at least 15 minutes before welding or heating.



SERVICE COOLING SYSTEM SAFELY

Explosive release of fluids from pressurized cooling system can cause serious burns.

Shut off engine. Only remove filler cap when cool enough to touch with bare hands. Slowly loosen cap to first stop to relieve pressure before removing completely.



SECTION “A” SAFETY

FILLING FUEL TANK



CAUTION: Handle fuel carefully. Do not fill the fuel tank when engine is running.

DO NOT smoke while filling fuel tank or servicing fuel system.

IMPORTANT: The fuel tank is vented through the filler cap. If a new filler cap is required, always replace it with an original vented cap.



WARNING

ELECTROCUTION HAZARD

DO NOT OPERATE THIS MACHINE WITHOUT PROPER GROUNDING

SECTION “A” SAFETY



**THIS MACHINE IS A HIGHLY
SPECIALIZED PIECE OF
EQUIPMENT THAT SHOULD BE
OPERATED ONLY BY
QUALIFIED PERSONNEL**

SECTION "B"

INTRODUCTION

FIG	DESCRIPTION	PAGE #
	INTRODUCTION	B-2

SECTION “B” INTRODUCTION



The Wagner-Smith Company Model T-3BWT-10-72H-FT4 is a hydrostatic bullwheel tensioner used for stringing up to three conductors at the same time. The purpose of the bullwheel is to remove the tension load off the reel of conductor and place it on the bullwheel modules. Bullwheel tensioners are used on both distribution and transmission projects.

The Wagner-Smith Company Model T-3BWT-10-72H-FT4 tensions cable or conductor that may be bent around a 72-inch diameter or 36-in radius wheel. This unit is capable of continuous line tension of 10,000 pounds at 4 miles per hour. The bullwheels provide tension to the line through the use of a hydraulic motor and gearbox combination. The tension is controlled by adjusting the hydraulic pressure in the system with an adjustable relief valve. The bullwheels can also be driven by the operator for pay-in or pay-out operations when not actively tensioning during a pull. Each bullwheel bundle can be operated independently. This unit features a Tier 4 final engine and a digital display that provides the operator with the real-time line tension and pull speed.

The manufacturer's manuals, if any, for the majority of this unit's components, are included to facilitate repairs should they become necessary.

SECTION "C" SPECIFICATIONS

FIG	DESCRIPTION	PAGE #
	SPECIFICATIONS	C-2-3

SECTION “C” SPECIFICATIONS

**WAGNER-SMITH
MODEL T-3BWT-10-72H-FT4**

**TRAILER MOUNTED
BULLWHEEL TENSIONER**

Specification No. 45072-36
Date 02/01/23

UNIT PERFORMANCE

Ratings per bullwheel set based on minimum 500 lbs. of tail tension from reel:

- Max Tension Rating..... 10,000 lbs. @ 4mph
- Max Speed Rating..... 5,000 lbs. @ 6 mph

BULLWHEEL TENSIONER

- Diameter..... 72 in. (bottom of groove)
- Groove Diameter..... 2.13 in.
- Number of Grooves..... 5
- Replacement Segments..... Yes
- Bullwheel Lining..... Elastomer (bolt-on)
- Tension Method..... Hydrostatic motor
- Bullwheel Offset..... Tilted for LH or RH lay conductor
- Tensioning..... Single/Two/Three conductor

POWERTRAIN

- Engine..... 74 HP Final Tier IV John Deere water-cooled
- Fuel Type..... Ultra Low Sulfur Diesel
- Fuel Capacity..... 19 Gallons
- Hyd. Reservoir..... 120 Gallons
- Heat Exchanger..... Hydraulically driven fan
- Tensioning..... Hydraulic with spring applied/hydraulic release brake

UNIT DIMENSIONS & WEIGHT

- Unit Length..... 46 ft. 00 in.
- Unit Width..... 08 ft. 06 in.
- Unit Height..... 12 ft. 06 in.
- Unit Weight (empty)..... 50,000 lbs.
- Tongue Weight (empty)..... 15,857 lbs.

SECTION "C"

SPECIFICATIONS

WAGNER-SMITH
MODEL T-3BWT-10-72H-FT4

TRAILER MOUNTED
BULLWHEEL TENSIONER

Specification No. 45072-36
Date 02/01/23

STANDARD FEATURES

- Steel Bullwheels Precision machined
- Engraved Control Panel Aluminum w/ blue powder coat
- Grounding Lugs Mounted front and rear
- Input Fairlead Multiple roller type
- Output Fairlead Single roller type
- Front Jack Manual Crank Type

SECTION "D"

DESCRIPTION OF INDIVIDUAL FUNCTIONS

FIG	DESCRIPTION	PAGE #
Figure 1	HYDRAULIC MOTOR WITH BRAKE	D-2
Figure 2	GEAR PUMPS	D-2
Figure 3	HYDRAULIC OIL RESERVOIR AND FILTERS	D-3
Figure 4	HYDRAULIC OIL HEAT EXCHANGER	D-3
Figure 5	BULLWHEELS	D-4
Figure 6	SYSTEM AIR COMPRESSOR	D-4
Figure 7...8	FAIRLEADS	D-5
Figure 9...17	OPERATOR CONTROL STAND	D-6-13

SECTION “D”

DESCRIPTION OF INDIVIDUAL FUNCTIONS

HYDRAULIC MOTOR WITH BRAKE

The unit uses a combination of two Rexroth motors and RR gearboxes (Fig. 1) to provide tension through the bullwheels using hydraulic pressure flowing over a relief valve. The hydraulic holding brake is built into the gearbox and is controlled manually from the operator's panel. If the circuit loses hydraulic pressure, the brake in the gearbox engages to prevent a line from dropping.



Figure 1: Hydraulic Motor w/ Brake

GEAR PUMPS

The gear pumps (Fig. 2) are driven by the John Deere diesel engine (Fig. 2). The first gear pump is used to provide charge pressure to both sides of the hydraulic motors. The second gear pump is used to control the haul-back feature (pull-in and pay-out). The machine's hydraulic oil heat exchanger is also fed from the second pump through the power beyond function in the valve used to drive the bullwheels.

NOTE: The engine should run at high idle (2,400 RPM) to provide sufficient flow from the pumps.

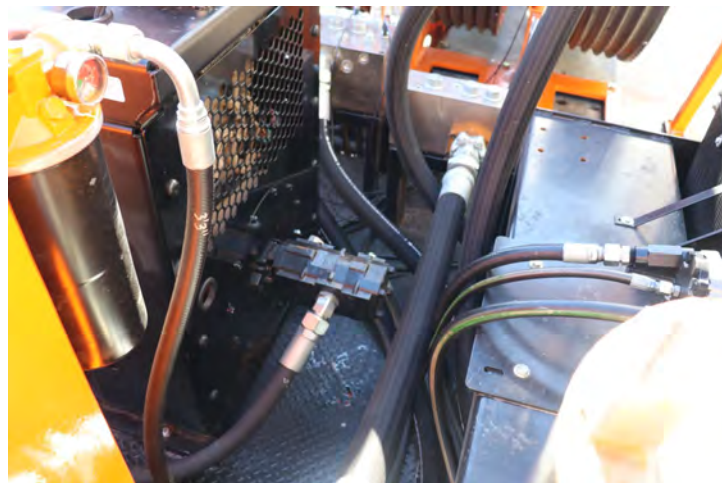

Figure 2: Engine & Gear Pumps

SECTION “D”

DESCRIPTION OF INDIVIDUAL FUNCTIONS

HYDRAULIC OIL RESERVOIR AND FILTERS

The purpose of the hydraulic oil reservoir (Fig. 3) is to provide hydraulic fluid to the pump. The purpose of the hydraulic filters (Fig. 3) is to clean the hydraulic oil as it circulates through the system.

NOTE: It is imperative that the hydraulic reservoir and filter be serviced at the recommended intervals. Cleanliness is the life of a hydraulic system.



Figure 3: Hydraulic Oil Reservoir & Filters

HYDRAULIC OIL HEAT EXCHANGER

The hydraulic oil heat exchanger (Fig. 4) keeps oil temperatures in safe operating range and extends the life of the hydraulic system. Oil temperature operating range is between 80°F to 180°F. When the hydraulic oil is below 110°F the oil bypasses the heat exchanger.



Figure 4: Hydraulic Oil Heat Exchanger

SECTION “D”

DESCRIPTION OF INDIVIDUAL FUNCTIONS

BULLWHEELS

The tensioner uses two 72 in. diameter bullwheels (Fig. 5) to provide tension to each line. The bullwheels use 5-groove elastomer segments that are bolted on. The front bullwheel is canted for left-hand or right-hand lay conductor. The segments can be switched out with 3-groove segments if needed.



Figure 5: Bullwheel

SYSTEM AIR COMPRESSOR

The system air compressor (Fig. 6) is located on the engine and supplies air to the reel stand brake system via a retractable air reel. The air pressure is adjusted at the control stand.



Figure 6: System Air
Compressor

SECTION “D”

DESCRIPTION OF INDIVIDUAL FUNCTIONS

FAIRLEADS

There are three fairlead assemblies on the unit. Two outer fairleads are used to keep the conductor off the unit and one input fairlead to guide the conductor onto the bullwheels.

Output Fairleads:

The front and rear fairleads (Fig. 7) are long to accommodate the position of the reel stand and first tower and keeps the conductor off the components on the unit.



Figure 7: Output Fairlead

Input Fairlead:

The input fairlead (Fig. 8) is used to guide the conductor into the bullwheel groove. It is installed so that the conductor feeds (viewed from the rear of the machine) into the left groove of the front bullwheel and exits from the right groove of the rear bullwheel to the tower.



Figure 8: Input Fairlead

SECTION “D”

DESCRIPTION OF INDIVIDUAL FUNCTIONS

OPERATOR CONTROL STAND

The operator control stand contains all the major control systems on the unit. The bullwheel drive controls (Fig. 10) and auxiliary connections (Fig. 10) are located below the control panel. All other system controls and the digital display are located on the control panel (Fig. 11).

Bullwheel Drive and Cab Extension Controls

- 1) **Mechanical control lever (Fig. 10A):** Drives bullwheels forward (pay-out) or reverse (pull-in). Pull handle up to pull-in and push handle down to pay-out. Use system pressure to regulate pull-in pressure. Do not use during tensioning process.

Auxiliary Connections

- 1) **Service port (Fig. 10B):** Service connection for WSE program (WSE access only)
- 2) **USB port (Fig. 10C):** Download pull data including: line tension, line speed, and distance pulled.
- 3) **12V port (Fig. 10D):** Use 12V adapter to power auxiliary systems.
- 4) **Battery studs (Fig. 10E):** Provides power to auxiliary systems.

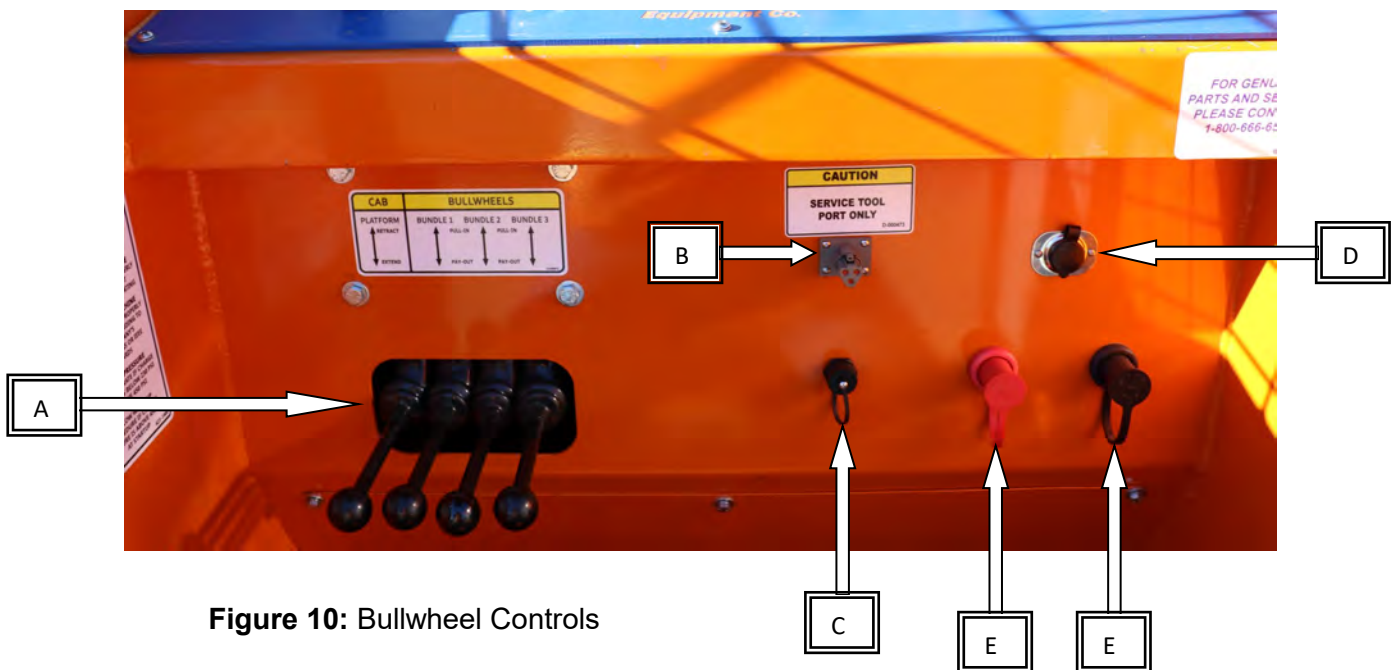

SECTION "D"

DESCRIPTION OF INDIVIDUAL FUNCTIONS

OPERATOR CONTROL STAND (cont.)

Control Panel

- 1) Engine controls (Fig. 11A):
 - a) **Ignition key switch:** A 4-position ignition switch: off (center), on (right), start (far right), acc (far left).
 - b) **Throttle toggle switch:** A 2-position toggle switch: low idle (down) and high idle (up). The engine is at 1,200 RPM at low idle and 2,400 RPM at high idle.
- 2) Bullwheel brake controls (Fig. 11B):
 - a) **Palm Valve:** Engages the bullwheel brake when depressed; It is also used for pre-setting pressures.
- 3) Reel stand brake controls (Fig. 11C):
 - a) **Air pressure knob:** A mechanical knob adjusts the air pressure delivered to a remote reel stand. Turning clockwise increases pressure and turning counter-clockwise decreases pressure.
- 4) Line tension control (Fig. 11D):
 - a) **System pressure knob:** A mechanical knob adjusts the hydraulic pressure to the bullwheels to control line tension. Turning clockwise increases pressure and turning counter-clockwise decreases pressure.
 - b) **System pressure gauge:** This gauge is used to monitor the hydraulic system pressure and cross reference the "Pressure vs. Tension" chart to determine line tension. The system pressure can also be found in the display (Fig. 11E).
- 5) Display and Buttons (Fig. 11E)
 - a) **Display:** Displays information relevant to the pulling/tensioning operation. Diagnostic information related to the engine and hydraulics system is also available on this screen
 - b) **Button Panels:** Used to navigate the display located at the center of the panel. Touch screen is also available, but is not recommended when wearing gloves



SECTION “D”

DESCRIPTION OF INDIVIDUAL FUNCTIONS

OPERATOR CONTROL STAND (cont.)

Control Panel (cont.)

The Murphy digital display (Fig. 11E) provides the operator with real time information about the engine, hydraulic system, and air system. Line pull data including line tension, pull speed, and pull distance are shown and can be downloaded to a USB drive. An alert system lets the operator know when unit parameters exceed the recommended values including for the John Deere engine. The display consists of the following six screens:

1) Home Screen (Fig. 12):

- a) Screen displayed after turning the unit on. Shows where each button on the display will take the operator. Also shows important engine lamps and fault codes at the bottom.



Figure 12: Home Screen

SECTION “D”

DESCRIPTION OF INDIVIDUAL FUNCTIONS

OPERATOR CONTROL STAND (cont.)

Control Panel (cont.)

2) Tension Controls Screen (Fig. 13):

- Line tension:** Indicates the calculated line tension with both a gauge and read-out.
- Speed:** Indicates the pull speed.
- Distance:** Indicates the distance pulled.
- Air brake pressure:** Indicates the air pressure supplied to the reel stand.
- Fuel level:** Indicates the engine’s fuel level as a percentage.

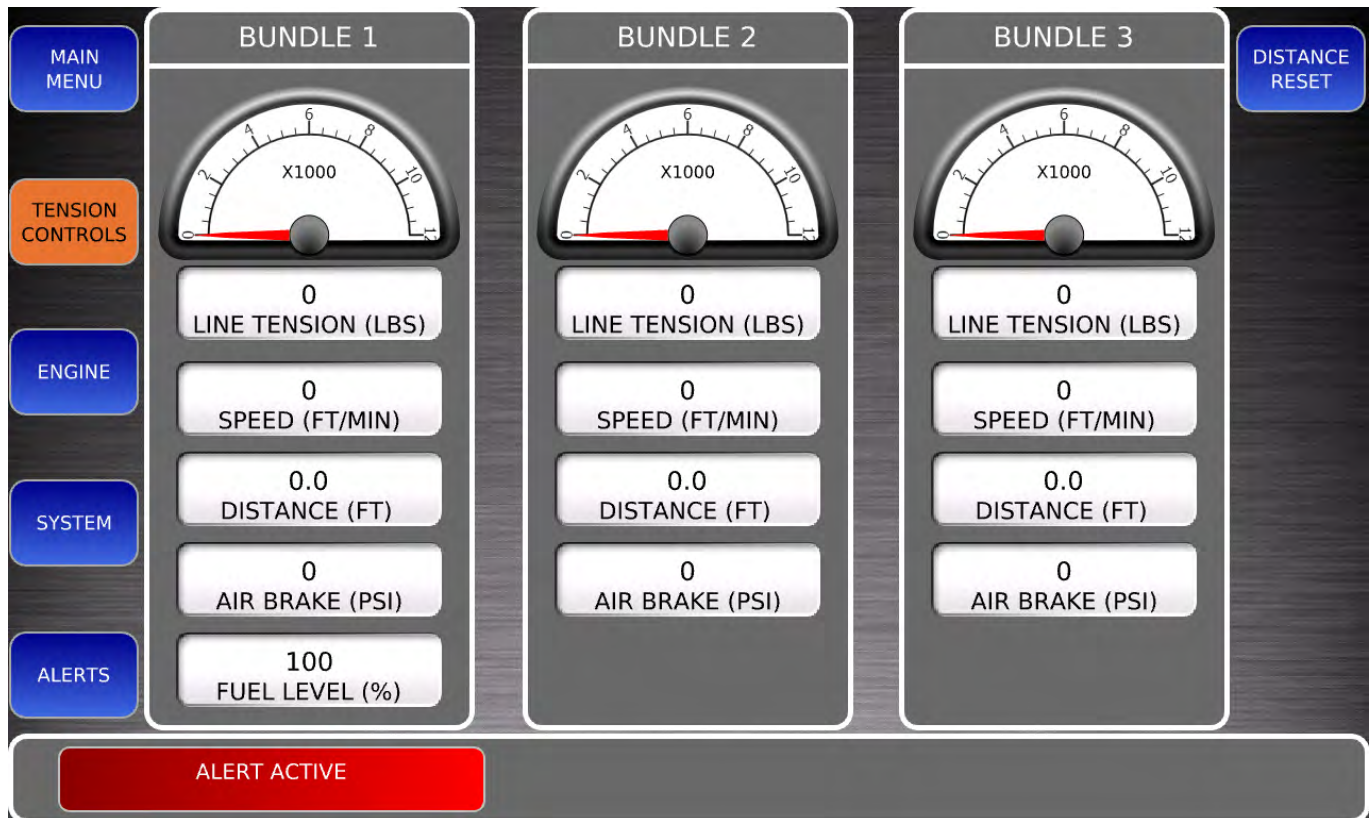

Figure 13: Tension Controls Screen

SECTION “D”

DESCRIPTION OF INDIVIDUAL FUNCTIONS

OPERATOR CONTROL STAND (cont.)

Control Panel (cont.)

3) Engine Screen (Fig. 14):

- a) **Tachometer:** Indicates engine RPM
- b) **Oil pressure gauge:** Indicates engine oil pressure.
- c) **Fuel gauge:** Indicates amount of fuel in the tank.
- d) **Coolant temperature gauge:** Indicates engine coolant temperature.
- e) **Voltmeter:** Indicates if the alternator is charging the battery or electrical system.
- f) **Engine hours:** Indicates the total hours the engine has ran.
- g) **Engine % load:** Indicates the load in percentage that is currently on the engine.

NOTE: see Appendix A John Deere Engine for a complete list of engine lamps and descriptions.



Figure 14: Engine Screen

SECTION "D"

DESCRIPTION OF INDIVIDUAL FUNCTIONS

OPERATOR CONTROL STAND (cont.)

Control Panel (cont.)

4) System Screen (Fig. 15):

- a) **System pressure:** Indicates the system (tension) pressure.
- b) **Charge pressure:** Indicates the charge pressure.
- c) **Hydraulic brake pressure:** Indicates the hydraulic brake pressure used to control the release of the holding brake.
- d) **Inlet temperature:** Indicates the hydraulic oil temperature before entering the heat exchanger.
- e) **Outlet temperature:** Indicates the hydraulic oil temperature after going through the heat exchanger.

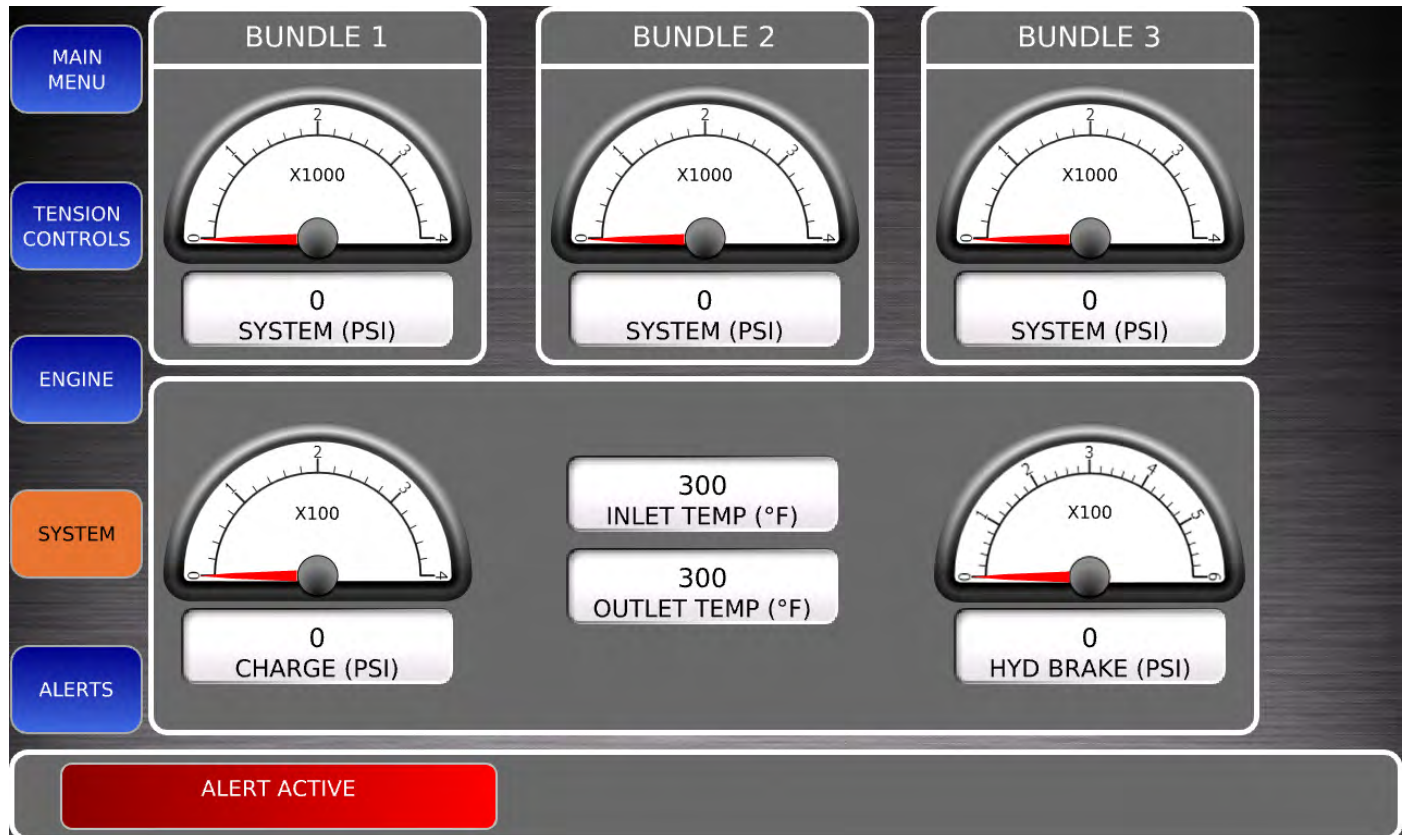

Figure 15: System Screen

SECTION “D”

DESCRIPTION OF INDIVIDUAL FUNCTIONS

OPERATOR CONTROL STAND (cont.)

Control Panel (cont.)

5) Alerts Screen (Fig. 16)

- a) **Charge pressure OK:** Sets the minimum value (150 psi) for the charge pressure before an alert is active.
- b) **Fuel level OK:** Sets the minimum value (3 gal.) for the fuel level before an alert is active.
- c) **Hydraulic temperature OK:** Sets the minimum/maximum values (80°F/180°F) for the hydraulic oil temperature before an alert is active.
- d) **Brake hydraulic pressure OK:** Sets the minimum/maximum values (350°F/420°F) for the hydraulic brake pressure before an alert is active.
- e) **Engine diagnostic message:** Displays diagnostic message sent from the engine that includes the Cummins fault codes.
- f) **Engine lamps:** Include: wait to start, water in fuel, check engine, stop engine.

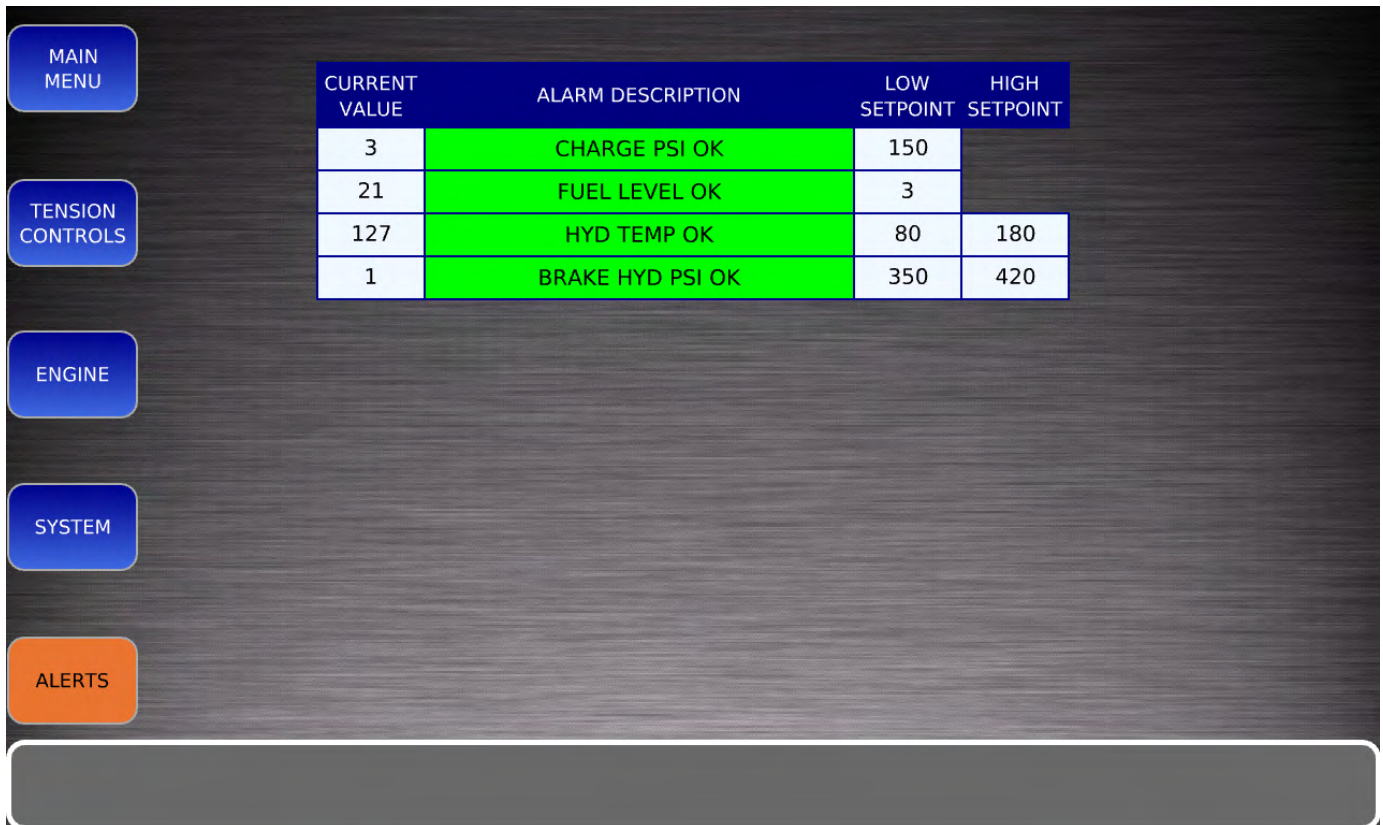

Figure 16: Alerts Screen

SECTION “D”

DESCRIPTION OF INDIVIDUAL FUNCTIONS

OPERATOR CONTROL STAND (cont.)

Control Panel (cont.)

6) Save Pull Data Screen (Fig. 17):

- a) Provides instructions for how to download pull data information to a USB drive. Insert a USB drive into the USB port on the side of the control stand and press the download button on the display. Once the screen updates with complete remove the USB drive.

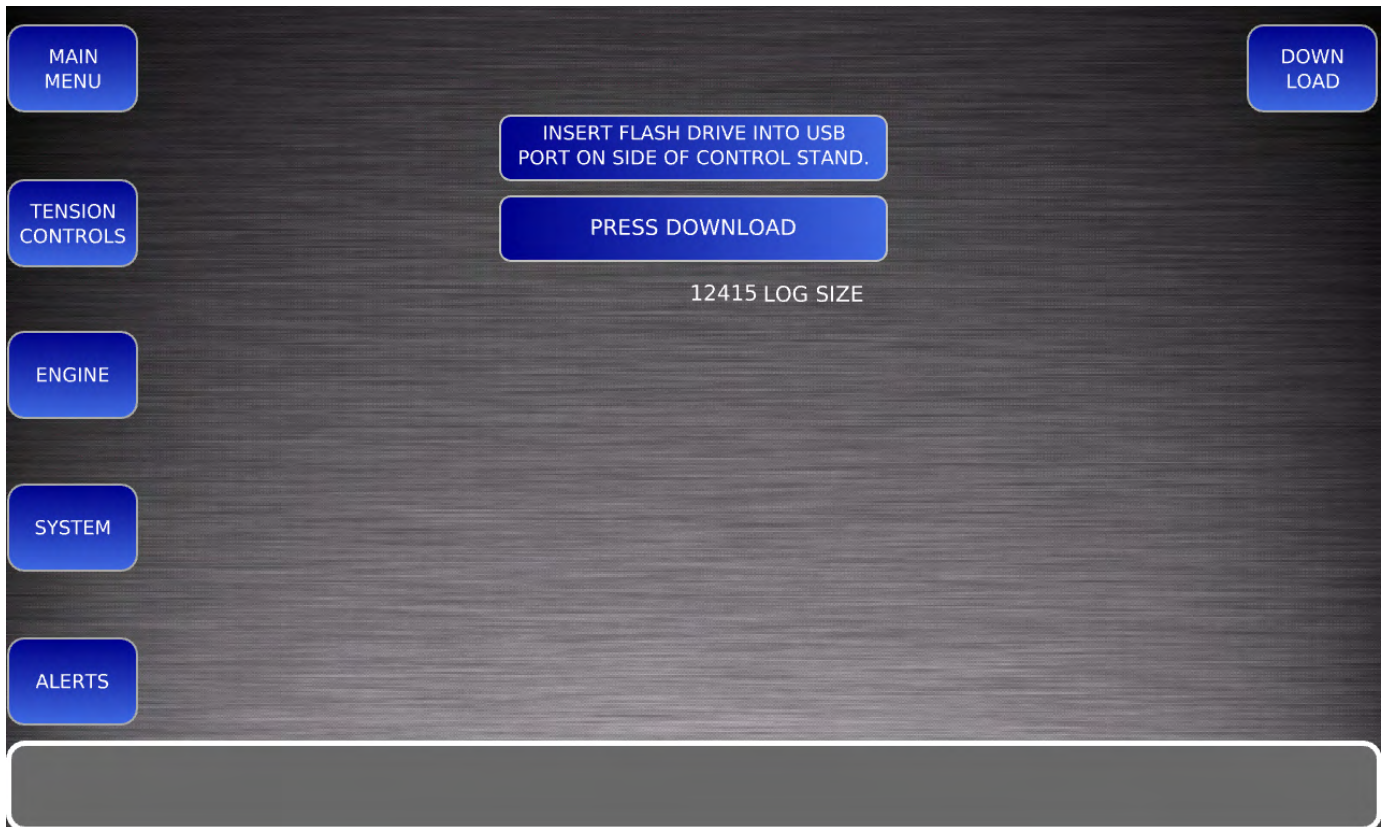

Figure 17: Save Pull Data Screen

SECTION "E" OPERATIONS

FIG	DESCRIPTION	PAGE #
	FIELD SET UP	E-2
	DAILY PREVENTATIVE MAINTENANCE	E-3
Figure 1	THREADING THE BULLWHEELS	E-3
Figure 3	DRIVING THE BULLWHEELS	E-4
Figure 4...5	TENSIONING	E-5

SECTION “E” OPERATIONS

FIELD SETUP

Position the Tensioner in line with the first pole or tower and back from the base at least one and a half (1-1/2) times the height of the pole or tower from the ground. (Example: If the utility pole or tower is 45 feet above the ground, the machine should be positioned approximately 65—75 feet ($45 \times 1.5 = 67.5$) from the base of the pole.) This will give a good fleet angle from the stringing block to the tensioner and will help decrease the line pull. After you position the tensioner, anchor it securely. Stabilize and level the unit. **Ground the unit properly** to prevent the unit from becoming electrically energized to avoid operator injury. Each unit has grounding bars already welded to it for the proper additional grounding attachments. Unit should be grounded to IEEE or your company’s standard procedures.

Field Setup Checklist:

- 1) Locate the unit on as level ground as possible.
- 2) Line it up with the conductor to be pulled.
- 3) Distance from the pole or tower should be a minimum of 1-1/2 times the height of the pole or tower from the ground.
- 4) Level the unit.
- 5) **Anchor unit securely** with anchors rated at or above the maximum rating of the machine.
- 6) **Ground unit** according to IEEE or your company’s standard procedures.

DAILY PREVENTATIVE MAINTENANCE

Perform daily maintenance to ensure that the machine operates as expected and at its rated values.

Daily maintenance checks are the following:

- 1) Before starting the engine, check:
 - a) Engine oil level.
 - b) Engine fuel level.
 - c) Hydraulic system oil level.
 - d) The hydraulic oil shutoff valve is open, turned fully counter-clockwise.
 - e) Hydraulic oil system pressure gauge reads zero.
- 2) After starting the engine, check:
 - a) Charge pressure gauge reads 190 to 200 psi at 2,400 RPM.
 - b) Brake control pressure gauge reads 390 to 410 psi at 2,400 RPM.
 - c) Check for any fluid leaks.
 - d) If there are any unusual noises, shut down engine immediately.
- 3) After engine shutdown, check:
 - a) Inspect for fluid leaks.
 - b) Inspect for loose bolts, pins, etc.
 - c) Hydraulic oil reservoir filler cap in place and secure.

SECTION “E” OPERATIONS

WARNING

MACHINE MUST BE ANCHORED AGAINST THE MAXIMUM RATING OF THE MACHINE.

MACHINE MUST BE PROPERLY GROUNDED ACCORDING TO IEEE OR YOUR COMPANY’S STANDARD PROCEDURES.

THREADING THE BULLWHEELS

Feed the conductor from the top of the conductor reel through the input fairlead assembly (Fig. 1A) to the left groove of the front bullwheel (Fig. 1B) (viewed from the rear), then into the left groove of the rear bullwheel (Fig. 1C). Continue this through each successive groove until the conductor leaves the rear bullwheel to the pole or tower. The conductor feeds from the left to the right when viewed from the input fairlead.

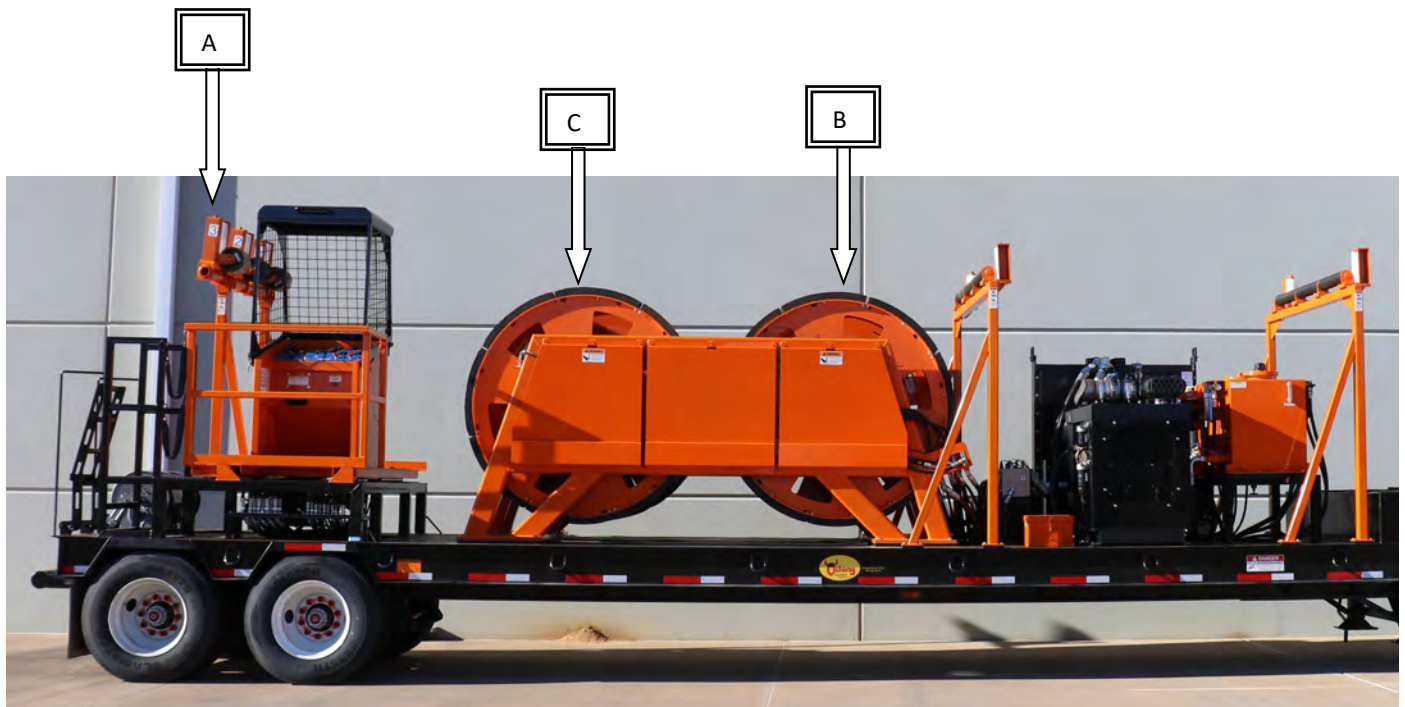

Figure 1: Threading the Bullwheels

SECTION “E” OPERATIONS

DRIVING THE BULLWHEELS (PAY-OUT AND PULL-IN)

- 1) Set engine speed to high throttle (2,400 RPM) (Fig. 2A).
- 2) Release hydraulic brake by pulling palm valve up to “Release” position (Fig. 2B).
- 3) Shift directional control lever (Fig. 3) on right side of control stand up (Pull-in) or down (Pay-out).

Note: When driving in pull-in (down) it may be necessary to increase pressure setting; this can be done by turning the system pressure knob (Fig. 2C) in the clockwise direction.



Figure 2: Control Panel



Figure 3: Bullwheel Control Lever

SECTION “E” OPERATIONS

TENSIONING

- 1) Ensure that at least 500 lbs. of tail tension (with no slack between let-off reel and bullwheels) is supplied by the let-off reel.
- 2) To set line tension:
 - a) If approximate line tension is known:
 1. Apply bullwheel brake (Fig. 2B).
 2. Set engine speed to high idle (2,400 RPM) (Fig. 2A)
 3. Adjust system pressure knob (Fig. 2C) to desired line tension (shown on display). Turn knob clockwise to raise tension or counter-clockwise to lower tension.
 4. Release hydraulic brake (Fig. 2B) and signal puller to begin pull.
 5. Adjust final tension after the pull is underway.
 - b) If line tension is not known:
 1. Apply bullwheel brake (Fig. 2B).
 2. Turn system pressure knob (Fig. 2C) in clockwise direction until the valve is bottomed out.
 3. Release bullwheel brake (Fig. 2B).
 4. Signal puller to begin taking up slack.
 5. When the line reaches the desired sag turn the system pressure knob (Fig. 2C) counter-clockwise until the line begins to move.
 6. Adjust final tension after pull is underway.
- 3) Ensure the hydraulic oil temperature is at least 80°F to 100°F before starting pull. If oil temperature rises up to 180°F signal the puller to slow the pull down until the temperature stabilizes. Maximum hydraulic oil temperature is 180°F.

Starting and Stopping:

- 1) Start the pull by releasing the brake (Fig. 2B) and signaling the puller to start. See tensioning above.
- 2) Stop the pull by signaling the puller to stop; when the conductor comes to a stop apply the brake (Fig. 2B).
- 3) When ready to start again, release the brake (Fig. 2B).
- 4) Signal the puller to start. If the system pressure knob (Fig. 2C) is in the same position when the pull was stopped then the conductor will pay-out at the same tension as before.

Note: If the unit is shut-off with the brake switch in the “release” position the brake will automatically apply and stay applied until the unit is turned on again and the brake switch is returned to the “apply” position.

WARNING

WHENEVER THE TAIL TENSION IS ALLOWED TO GO SLACK (SUCH AS WHEN CHANGING CONDUCTOR REELS, ETC.), CONDUCTOR GRIPS MUST BE USED TO CATCH OFF THE CONDUCTOR AT THE FRONT OF THE MACHINE.

NEVER ALLOW SLACK IN THE TAIL LINE. WHEN CHANGING REELS ALWAYS WIND THE SLACK BACK ONTO THE LET-OFF REEL BEFORE THE TENSIONING OPERATION IS STARTED.

SECTION "F"

ROUTINE MAINTENANCE

FIG	DESCRIPTION	PAGE #
Figure 1...8	BEFORE STARTING ENGINE	F-2-5
Figure 9...11	AFTER STARTING ENGINE	F-6-7
	50 HOUR INSPECTION	F-8
Figure 12	100 HOUR INSPECTION	F-8
Figure 13	HYDRAULIC SYSTEM	F-9
	COMPONENT SERVICING	F-9

SECTION “F”

ROUTINE MAINTENANCE



The Wagner-Smith Equipment Company Model T-3BWT-10-72H-FT4 is a self contained trailer mounted bullwheel tensioner with auxiliary reel stand air brake controls. This unit must be given regular care and operated in accordance with the instructions provided in this document.

It is imperative that the advanced hydraulic system incorporated by this design be kept clean. It is suggested that a good periodic preventative maintenance schedule be followed in maintaining this unit.

Upon receipt, this unit should be checked for damage from shipping. In addition, the following checks should be made:

Before Starting Engine Check:

- 1) All mounting bolts and nuts for tightness.
- 2) Check the engine oil level:
- 3) Do the following **BEFORE STARTING THE ENGINE** for the first time each day:
 - a) Check engine oil level on dipstick (Fig. 1). Do not operate engine when oil level is below the ADD mark on dipstick.
 - b) Add oil at filler cap as required, using seasonal viscosity grade oil. (Refer to Appendix A)

IMPORTANT: DO NOT add makeup oil until the oil level is BELOW the add mark.

NOTE: Always keep oil level within the crosshatch pattern on dipstick when operating engine. Oil levels anywhere within crosshatch are considered full.

SECTION “F”

ROUTINE MAINTENANCE

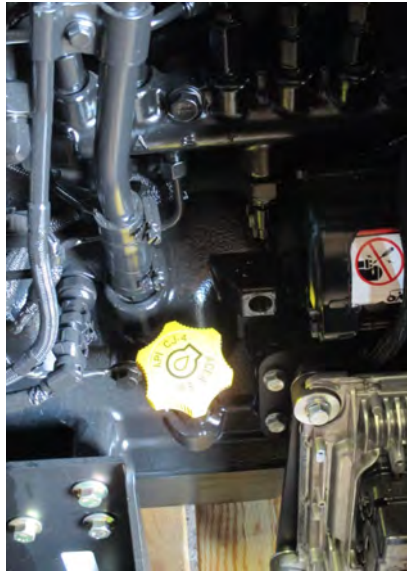

Figure 1: Engine Dipstick

- 4) Check coolant system level:
 - a) Check the coolant level when the engine is cold. Coolant level should be at bottom of filler neck. Fill the radiator with proper coolant solution if the level is low. (Refer to Appendix A)

CAUTION: Explosive release of fluids from pressurized cooling system can cause serious burns. Only remove the filler cap when the engine is cold or when cool enough to touch with bare hands. Slowly loosen the cap to first stop to relieve pressure before removing completely.

- 5) Check overall cooling system for leaks.
- 6) Check throttle linkage:
 - a) Lubricate throttle linkage. Move throttle lever back and forth to check for binding.
- 7) Check fuel filters:
 - a) Periodically drain to remove water or debris and bleed the fuel system (Refer to Appendix A)

IMPORTANT: Drain water into suitable container and dispose of properly.

SECTION “F”

ROUTINE MAINTENANCE



Figure 3: Secondary Fuel Filter



Figure 4: Primary Fuel Filter

8) Inspect:

- a) Radiator for leaks and trash buildup.
- b) Air intake system hoses and connections for cracks and loose clamps.
- c) Fan, alternator, and accessory drive belts for cracks, breaks, or other damage.
- d) Water pump for coolant leaks.

NOTE: Wipe all fittings, caps, and plugs before performing any maintenance to reduce the chance of system contamination.

NOTE: It is normal for a small amount of leakage to occur as the engine cools down and parts contract. Excessive coolant leakage may indicate the need to replace the water pump seal. Contact your engine distributor or servicing dealer for repairs.

10) Check hydraulic system oil level (Fig. 5):

- a) Oil level must be on full mark before daily startup.



Figure 5: Hydraulic Oil Level Gauge w/ Temperature Indicator

SECTION “F”

ROUTINE MAINTENANCE

11) Hydraulic reservoir shutoff valve is open (Fig. 6):

- a) The shutoff valve is located in the suction line of the pump, between the reservoir and filter. Turn the valve handle counter-clockwise until fully opened. When the system needs service turn the valve handle clockwise until fully closed.

NOTE: These valves are tie wrapped from the factory in the full open position to prevent accidental closing.



Figure 6: Hydraulic Oil Reservoir Shutoff Valve

12) Check fuel gauge (Fig. 7):



Figure 7: Digital Fuel Gauge

12) Line tension on display should read zero (Fig. 8):



Figure 8: Digital Line Tension Gauge

SECTION "F"

ROUTINE MAINTENANCE

After Starting Engine Check:

- 1) For any fuel leaks.
- 2) For any hydraulic oil leaks.
- 3) Check hydraulic functions:
 - a) Set engine throttle to high idle (2,400 RPM) (Fig. 9A).
 - b) Charge pressure gauge should read 190-200 psi (Fig. 10A).
 - c) Brake release gauge should read 390-410 psi (Fig. 10B).
 - d) Apply brake (Fig. 9B).
 - e) Shift directional control lever up (pull-in) (Fig. 11).

NOTE: Pressure control valves are used to control line tension when tensioning the conductor. Line speed is controlled by the puller.



Figure 9: Control Panel

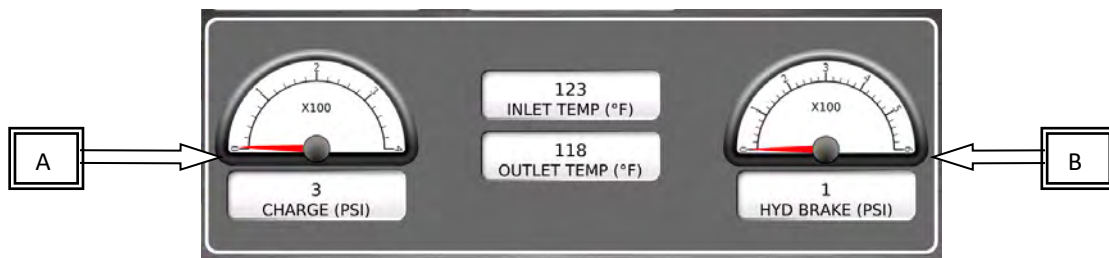

Figure 10: Digital Gauges

SECTION "F"

ROUTINE MAINTENANCE

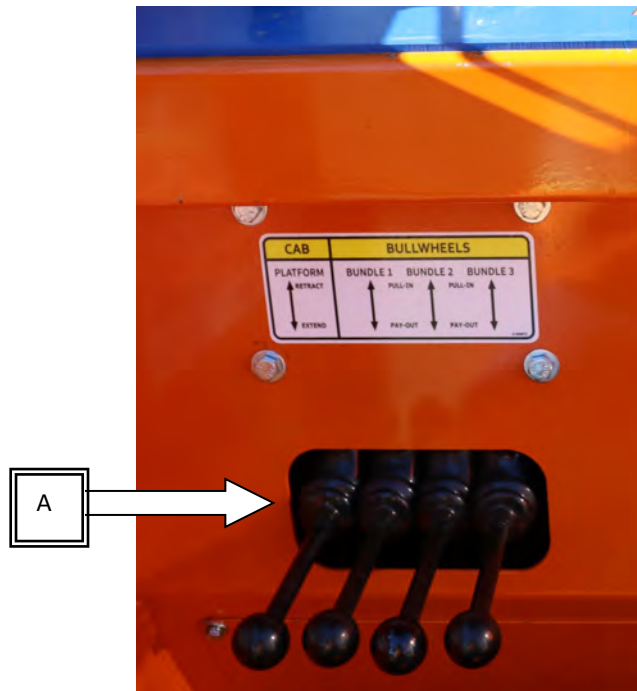

Figure 11: Bullwheel Drive Controls

Check Bullwheel Drive:

- 1) Release brakes (Fig. 9B).
- 2) To rotate bullwheels in pay-out (forward) direction shift directional control lever down (Fig. 11).
- 3) To rotate bullwheels in pull-in (reverse) direction shift direction lever up (Fig. 11).

NOTE: It may be necessary to increase system pressure before bullwheels will rotate in pull-in (reverse) direction.

Daily Inspection Checklist:

- 1) Before starting the engine check:
 - a) Engine oil level (Fig. 1).
 - b) Engine fuel level (Fig. 7).
 - c) Hydraulic system oil level (Fig. 5).
 - d) The hydraulic oil shutoff valve is open, turned full clockwise (Fig. 6).
 - e) Hydraulic oil system pressure gauge reads zero.
- 2) After starting the engine check:
 - a) Charge pressure gauge (Fig. 10A) reads 190-200 psi and brake release pressure gauge (Fig. 10B) reads 390-410 psi when engine is at high idle (2,400 RPM).
 - b) Check for any fluid leaks.
 - c) If there are any unusual noises, shut down engine immediately.
- 3) After engine shutdown check:
 - a) For any fluid leaks.
 - b) Loose nuts and bolts.
 - c) Hydraulic oil reservoir filler cap in place and secure (Fig. 2).

SECTION “F”

ROUTINE MAINTENANCE

50 HOUR INSPECTION

- 1) Check for water in hydraulic oil (water will cause the oil to look milky).

100 HOUR INSPECTION

- 1) Perform 50 hour inspection.
- 2) Check both batteries fluid levels (Fig. 12).



Figure 12: Batteries

Because the batteries are the “heart” of the electrical system, periodic checks are necessary to keep it functioning properly. Keep the battery fluid level to the bottom of the filler neck with distilled water. If water is added during freezing weather, run the engine 20 to 30 minutes before shutting it off. This mixes the added water with the electrolyte and will prevent it from freezing and damaging the battery. Have the battery charge checked regularly during extreme cold weather.

Keep battery clean by wiping it with a damp cloth. Keep all connections clean and tight. Remove any corrosion, and wash terminals with a solution of 1 part baking soda and 4 parts water. Tighten all connections securely.

Coat the battery terminals and connectors with a mixture of petroleum jelly and baking soda to slow corrosion.

CAUTION: Keep fire away from the top of open battery cells. Combustible gas is always present.

SECTION “F”

ROUTINE MAINTENANCE

HYDRAULIC SYSTEM

- 1) Change hydraulic oil and hydraulic oil filters when filter gauges display in the red:
 - a) Before removing the oil filter elements (Fig. 13), turn off the oil flow to the filter by closing the valves. (Fig. 6) After replacing the filter, be sure to re-open the valves (Fig. 6) before restarting the system.
 - b) It may be necessary to change the fluid more frequently than the above intervals if the fluid becomes contaminated with foreign matter (dirt, water, grease, etc.) or if the fluid has been subjected to temperature levels greater than the recommended maximum. Never reuse fluid.
 - c) The filters should be changed whenever the fluid is changed or whenever the filter indicators show that it is necessary to change the filters. Hydraulic fluid for all Wagner-Smith hydraulic systems is **Chevron Rando HDZ ISO Grade 46**. Consult Wagner-Smith before using any other hydraulic fluids.

CAUTION: Do not mix hydraulic fluids.



Figure 13: Hydraulic Oil Filters

Engine Operation

Break-In Service

Extra care during the first 100 hours of operation results in satisfactory long-term engine performance and life.

1. This engine is factory-filled with John Deere Break-In Plus™ oil. Operate the engine at heavy loads with minimal idling during the break-in period.
2. If the engine has significant operating time at idle, constant speeds, and/or light load usage, or additional oil is required in the first 100 hour period, a longer break-in period may be required. In these situations, an additional 100 hour break-in period is recommended using a new change of John Deere Engine Break-In Plus Oil and a new John Deere oil filter.
3. Check oil more frequently during engine break-in period. If oil must be added during this period, John Deere Break-In Plus Oil is preferred. See John Deere Break-In Plus™ Engine Oil — Interim Tier 4, Final Tier 4, Stage IIIB, and Stage IV in the Fuels, Lubricants, and Coolants Section for other oils allowed.

IMPORTANT: DO NOT fill above the top of the crosshatch pattern or the FULL mark, whichever is present. Oil levels anywhere within crosshatch are considered in the acceptable operating range. John Deere Break-In Plus engine oil should be used to make up any oil consumed during the break-in period.

4. During the first 20 hours, avoid prolonged periods of engine idling. If engine idles longer than 5 minutes, stop engine.
5. During the initial operation of a new or rebuilt engine with Break-In Plus, change the oil and filter between a minimum of 100 hours and a maximum of up to

Break-In Plus is a trademark of Deere & Company

500 hours (B). (Top-load oil filter illustrated.) (See Changing Engine Oil and Replacing Filter in the Lubrication & Maintenance — 500 Hours/12 Months Section.) Fill crankcase with seasonal viscosity grade oil. (See Diesel Engine Oil — Interim Tier 4, Final Tier 4, Stage IIIB, and Stage IV in the Fuels, Lubricants, and Coolants Section.)

NOTE: Some increase in oil consumption may be expected when low viscosity oils are used. Check oil levels more frequently.

If temperature is below 0 °C (32 °F), it may be necessary to use cold weather starting aids (See Cold Weather Operation in the Engine Operation Section).

If air temperature is below 0 °C (32 °F), use an engine block heater.

6. Watch coolant temperature gauge closely during engine operation. If coolant temperature rises above 113 °C (235 °F), the engine reduces power automatically. Unless temperature drops quickly, stop the engine and determine the cause before resuming operation.

Monitor oil pressure and coolant temperature to ensure that they are within specification.

Specification

Engine —Oil Pressure at Full Load Rated Speed.....	370 kPa (3.70 bar) (54 psi)
Minimum Oil Pressure at Low Idle	150 kPa (1.50 bar) (22 psi)
Coolant Temperature Range.....	85°–97 °C (185°–207 °F)

7. Check belt for proper seating in pulley grooves.

AT89373,0000002 -19-08FEB18-1/1

Generator Set (Standby) Applications

To assure that your engine will deliver efficient standby generator operation when needed, start engine and run at rated speed (with 50%—70% load) for 30 minutes every 2 weeks. DO NOT allow engine to run for an extended period of time with no load.

Biodiesel fuel is not recommended for standby equipment that can have minimal fuel consumption (such as standby generators, fire protection, etc.). For standby applications,

use only petroleum based diesel fuel with John Deere approved fuel conditioners and additives. For fuel conditioners and additives, check with your local John Deere dealer.

Petroleum diesel fuel should not be stored in service tanks longer than two years even when using fuel additives. See your fuel distributor or John Deere dealer for more information.

RK80614,0000009 -19-16OCT12-1/1

Passive Regeneration

Periodically, the exhaust filter experiences higher temperature levels simply through the engine operating at higher loads. During these times, the higher exhaust temperature cleans a small amount of soot build-up in the exhaust filter. Conversely, unnecessary idling can

cause additional exhaust filter soot to accumulate. For the best possible engine operation which requires the least amount of operator interaction, work engine at higher load conditions whenever possible and keep idling to a minimum.

RK80614,000001A -19-09MAY16-1/1

Automatic (AUTO) Exhaust Filter Cleaning

NOTE: Operator display icons and procedures can vary in other applications. The information contained in this section specifically applies to only OEM engines. If you are operating a vehicle, please see the vehicle operator manual for exhaust filter cleaning and handling information and procedures.

Operating the engine in AUTO Mode allows the ECU to perform intelligent exhaust filter cleaning as required. The Exhaust Filter Cleaning Indicator will illuminate when the system is actively performing an exhaust filter cleaning. During this process, the doser will inject small amounts of fuel into the exhaust stream to assist in cleaning the exhaust filter. When the exhaust filter cleaning process has completed its cycle, the cleaning indicator will automatically turn off.

CAUTION:
Servicing machine or attachments during exhaust filter cleaning can result in serious personal injury. Avoid exposure and skin contact with hot exhaust gases and components.

During auto or manual/stationary exhaust filter cleaning operations, the engine will run at elevated idle and hot temperatures for approximately 30 minutes. Exhaust gases and exhaust filter components reach temperatures hot enough to burn people, ignite, or melt common materials.

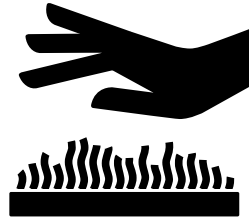

RG17488 —UN—21AUG09

CAUTION: If the machine is not in a safe location for elevated exhaust temperatures, move the machine to a safe location and check for adequate fuel level before beginning the exhaust filter cleaning process. Any PTO driven devices (if equipped) should be powered off or disconnected.

If the machine is not able to be moved into a safe location, the operator should temporarily disable auto exhaust filter cleaning (see Disable Exhaust Filter Cleaning later in this section). If the machine is located in a safe location, the auto mode should always be enabled.

JR74534,00001E7 -19-21MAR16-1/1

Manual/Parked Exhaust Filter Cleaning

NOTE: Operator display icons and procedures can vary in other applications. The information contained in this section specifically applies to only OEM engines. If you are operating a vehicle, please see the vehicle operator manual for exhaust filter cleaning and handling information and procedures.

Manual/Parked Exhaust Filter Cleaning is an automated process initiated at the request of the operator. This process allows the system to clean the exhaust filter when the operator previously needed to engage the disable exhaust filter cleaning because of specific conditions. During the process the engine speed will be controlled by the ECU and the machine must remain parked to complete the procedure. Time required for the Manual/Parked Exhaust Filter Cleaning process is dependent upon the level of exhaust filter restriction, ambient temperatures, and current exhaust gas temperature.

Complete cleaning times will vary on several criteria including fuel type, oil type, duty cycle, and the number of previously aborted exhaust filter cleaning requests. Average time for a standard cleaning can range from 20-50 minutes or longer.

CAUTION:

Servicing machine or attachments during exhaust filter cleaning can result in serious personal injury. Avoid exposure and skin contact with hot exhaust gases and components.

During auto or manual/parked exhaust filter cleaning operations, the engine will run at elevated idle and hot temperatures for approximately 30 minutes. Exhaust gases and exhaust filter components reach temperatures hot enough to burn people, ignite, or melt common materials.

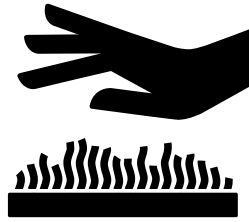

RG17488—JN—21AUG09

 CAUTION: Always park the machine in a safe location and check for adequate fuel level before beginning the exhaust filter cleaning process. Any PTO driven devices (if equipped) should be powered off or disconnected.

The exhaust filter indicator will remain off when Filter Cleaning is complete. If you are not returning the machine to service immediately after the procedure, allow the engine and the exhaust filter time to return to normal operating temperature before stopping engine. At any time during the parked procedure, the process can be canceled

Avoid disabling the cleaning procedure unless absolutely necessary. Repeated disabling or ignoring prompts to perform a manual/parked cleaning procedure will cause additional engine power limitations and can eventually lead to dealer required service.

Utilize Exhaust Filter Cleaning AUTO mode to avoid additional service.

JR74534.00001E8 -19-21MAR16-1/1

Disable Exhaust Filter Cleaning

NOTE: Operator display icons and procedures can vary in other applications. The information contained in this section specifically applies to only OEM engines. If you are operating a vehicle, please see the vehicle operator manual for exhaust filter cleaning and handling information and procedures.

NOTE: Disabling the exhaust filter cleaning request is not preferred. Disable the automatic exhaust filter

cleaning only when necessary. Whenever possible, cleaning should be allowed and the diagnostic gauge should be left in the auto mode. When left in auto mode, soot buildup in the exhaust filter system will be at a minimum.

NOTE: When AUTO or PARKED/MANUAL cleaning is enabled, the exhaust temperature may be high under no load or light load conditions at certain times during the exhaust filter cleaning cycle. Disable exhaust filter cleaning in conditions where it may be unsafe for elevated exhaust temperatures.

JR74534.00001E9 -19-21MAR16-1/1

Exhaust Filter Service Required

The exhaust filter cleaning procedures listed earlier in this section clean the soot from your exhaust filter. The exhaust filter also traps ash deposits over time which are not removed during an exhaust filter cleaning. When the exhaust filter has run several thousand hours, these

ash deposits can restrict engine performance due to increased back pressure. To correct this situation, replace the exhaust filter or have the exhaust filter cleaned in specialized equipment. See Diesel Particulate Filter Maintenance and Service in the Aftertreatment Section.

RK80614,000001E -19-11JUL13-1/1

Lubrication and Maintenance

Required Emission-Related Information

Service Provider

A qualified repair shop or person of the owner's choosing may maintain, replace, or repair emission control devices and systems with original or equivalent replacement parts. However, warranty, recall, and all other services paid for by John Deere must be performed at an authorized John Deere service center.

DX,EMISSIONS,REQINFO -19-12JUN15-1/1

Observe Service Intervals

In an emergency, where an authorized John Deere service location is not available, repairs may be performed at any available service establishment, or by the owner, using any replacement part, provided such parts are warranted by their manufacturer to be the equivalent of John Deere parts in performance and durability and the failure does not arise from the owner's failure to perform required maintenance.

Using hour meter (A) as a guide, perform all services at the hourly intervals indicated on following pages. At each scheduled maintenance interval, perform all previous maintenance operations in addition to the ones specified. Keep a record of hourly intervals and services performed, using charts provided in Lubrication and Maintenance Records section.

IMPORTANT: Recommended service intervals are for normal operating conditions. Perform maintenance at interval which occurs first, for example, either at 500 hours of operation or every 12 months. Service more often if engine operated under adverse conditions. Neglecting maintenance can result in failures or permanent damage to the engine.

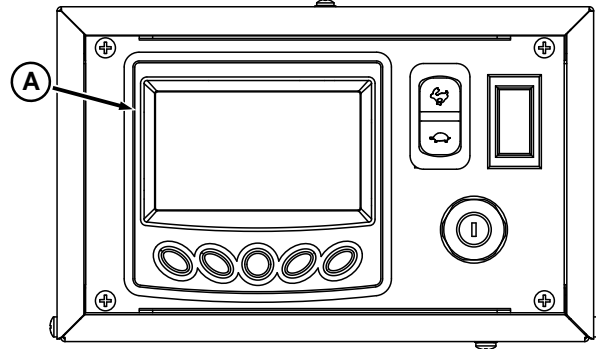

Hour Meter On Instrument Panel

A—Hour Meter

Perform all services at the hourly intervals. Record the services performed in the Lubrication and Maintenance Records Section. When scheduled service at any hourly level is performed, also perform all subordinate hourly level services.

Main Service	Subordinate Services			
	500 Hours	1500 Hours	3000 Hours	6000 Hours
500 Hours	X			
1500 Hours	X	X		
3000 Hours	X	X	X	
6000 Hours	X	X	X	X

ZE59858,0000014 -19-20NOV17-1/1

Use Correct Fuels, Lubricants, and Coolant

IMPORTANT: Use only fuels, lubricants, and coolants meeting specifications outlined in Fuels, Lubricants, and Coolant Section when servicing your John Deere Engine.

Consult your John Deere Servicing Distributor or your nearest John Deere Parts Network for recommended fuels, lubricants, and coolant. Also available are necessary additives for use when operating engines in tropical, arctic, or any other adverse conditions.



RG17133—JUN—18MAY09

RK80614,000020 -19-16OCT12-1/1

Lubrication and Maintenance Service Interval Chart

Item	Lubrication and Maintenance Service Intervals						As Required
	Daily/Before Every Startup	500 Hours of Operation or Every 12 Months	1500 Hours of Operation	1500 Hours of Operation or Every 36 Months	3000 Hours of Operation or Every 36 Months	6000 Hours of Operation or Every 72 Months	
Check Engine Oil	•						
Check Coolant Level	•						
Drain Water From Fuel Filters	•						
Check Air Cleaner Dust Valve Restriction Indicator Gauges	•						
Perform Inspection of Engine Compartment	•						
Service Fire Extinguisher		•					
Service Battery		•					
Change Engine Oil And Replace Oil Filter ^{a, b}		•					
Check Coolant Pump Weep Hole		•					
Check Open Crankcase Vent (OCV) System		•					
Replace Fuel Filter Elements		•					
Check Belt Tensioner and Belt Wear		•					
Check Cooling System		•					
Pressure Test Cooling System		•					
Check Engine Speeds		•					
Check Engine Mounts		•					
Check Engine Ground Connection		•					
Change Open Crankcase Ventilation (OCV) Filter ^c			•				
Change DEF Dosing Unit Filter				•			
Replace DEF Tank Header Suction Screen				•			
Adjust Engine Valve Clearance					•		
Test Glow Plugs for Continuity					•		
Flush and Refill Cooling System						•	
Test Thermostats						•	
Drain Water From Fuel Filters When Alarm Sounds							•
Add Coolant							•
Clean DEF Tank							•
Pre-Start Cleaning Guide							•
Service Air Cleaner Filter Elements							•
Clean Diesel Particulate Filter ^c							•
Replace Alternator/Fan Belt							•
Check Fuses							•
Check Electrical Wiring and Connections							•
Check Air Compressors (If Equipped)							•
Check Refrigerant (A/C) Compressor (If Equipped)							•
Replace Aftertreatment DEF Dosing System Coolant Filter							•

^aDuring the initial operation of a new or rebuilt engine with Break-In Plus, change the oil and filter between a minimum of 100 hours and a maximum of up to 500 hours.

^bService intervals depend on sulfur content of the diesel fuel, oil pan capacity, and the oil and filter used. (See Diesel Engine Oil and Filter Service Intervals in the Fuels, Lubricants, and Coolants Section.)

^cActual service should take place when the dash indicator light comes on or as indicated by the diagnostic gauge.

ZE59858,0000015 -19-20NOV17-1/1

Lubrication & Maintenance — Daily

Daily Prestarting Checks

Check the following items BEFORE STARTING THE ENGINE for the first time each day:

- Check engine oil level on dipstick. Fill cap/dipstick may be located on left or right side, depending on application. Add as required, using seasonal viscosity grade oil. (See Diesel Engine Oil — Interim Tier 4, Final Tier 4, Stage IIIB, and Stage IV in the Fuels, Lubricants, and Coolants Section for oil specifications.)

NOTE: Wipe all fittings, caps, and plugs before performing any maintenance to reduce the chance of system contamination.

- Check the coolant level when engine is cold. Fill radiator or surge tank with proper coolant if level is low. (See Adding Coolant in the Service As Required Section.) Check overall cooling system for leaks.
- Check radiator for leaks and trash buildup.

NOTE: It is normal for a small amount of coolant to weep from the coolant pump weep hole, especially as the engine cools down and parts contract. If enough coolant weeps from the engine where coolant drips from the engine, this

may indicate the need to replace the coolant pump seal. Contact your engine distributor or servicing dealer for repairs.

- Check fan, alternator, and accessory drive belts for cracks, breaks or other damage.
- Loosen water drain valve on each fuel filter all the way so that the valve opens to drain water and debris as needed. Retighten valves securely.

NOTE: Any water in fuel is drained into the bottom of the fuel filters. The operator is signaled by an amber indicator on the instrument panel. To service, see Drain Water From Fuel Filters in the Service As Required Section.

- Squeeze the automatic dust unloader valve (if equipped) on air cleaner assembly to clear away any dust buildup.
- Check air intake restriction indicator gauge and service air cleaner as required (if equipped).
- Check air intake system hoses and connections for cracks and loose clamps.
- Inspect the engine compartment. Look for fluid leaks, worn fan and accessory drive belts, loose connections, and trash buildup. Remove trash buildup and have repairs made as needed.

RK80614,0000023 -19-05FEB14-1/1

Lubrication & Maintenance — 500 Hours/12 Months

Servicing Fire Extinguisher

A fire extinguisher (A) is available from your authorized servicing dealer or engine distributor.

Read and follow the instructions which are packaged with it. The extinguisher should be inspected at least every 500 hours of engine operation or every 12 months. Once extinguisher is operated, no matter how long, it must be recharged. Keep record of inspections on the tag which comes with the extinguisher instruction booklet.

A—Fire Extinguisher



Fire Extinguisher

RK80614,0000024 -19-16OCT12-1/1

RW4918 —UN—15DEC88

Servicing Battery

CAUTION: Battery gas can explode. Keep sparks and flames away from batteries. Use a flashlight to check battery electrolyte level.

Never check battery charge by placing a metal object across the posts. Use a voltmeter or hydrometer.

Always remove grounded **NEGATIVE (—)** battery clamp first and replace it last.

WARNING: Battery posts, terminals, and related accessories contain lead and lead compounds, chemicals known to the State of California to cause cancer and reproductive harm. **Wash hands after handling.**

IMPORTANT: Wear personal Protective Equipment while doing any type of Battery check or replacement.

1. On regular batteries, check electrolyte level. Fill each cell to bottom of filler neck with distilled water.

NOTE: Low-maintenance or maintenance-free batteries should require little additional service. However, electrolyte level can be checked by cutting the center section of decal on dash-line, and removing cell plugs. Fill each cell to bottom of filler neck with distilled water.

2. Keep batteries clean by wiping them with a damp cloth. Keep all connections clean and tight. Remove



Exploding Battery

any corrosion, and wash terminals with a solution of 1 part baking soda and 4 parts water. Tighten all connections securely.

NOTE: Coat battery terminals and connectors with a mixture of petroleum jelly and baking soda to retard corrosion.

3. Keep battery fully charged, especially during cold weather. If a battery charger is used, turn off charger before connecting charger to battery(ies). Attach **POSITIVE (+)** battery charger lead to **POSITIVE (+)** battery post. Then attach **NEGATIVE (—)** battery charger lead to a good ground.

Continued on next page

ZE59858,0000016 -19-28JUL14-1/2

T5204 —UN—15APR13

CAUTION: Sulfuric acid in battery electrolyte is poisonous. It is strong enough to burn skin, eat holes in clothing, and cause blindness if splashed into eyes.

Avoid the hazard by:

1. Filling batteries in a well-ventilated area.
2. Wearing eye protection and rubber gloves.
3. Avoiding breathing fumes when electrolyte is added.
4. Avoiding spilling or dripping electrolyte.
5. Using proper jump start procedure.

If you spill acid on yourself:

1. Flush your skin with water.
2. Apply baking soda or lime to help neutralize the acid.
3. Flush your eyes with water for 10—15 minutes. Get medical attention immediately.

If acid is swallowed:

1. Drink large amounts of water or milk.
2. Then drink milk of magnesia, beaten eggs, or vegetable oil.
3. Get medical attention immediately.

In freezing weather, run engine at least 30 minutes to ensure thorough mixing after adding water to battery.

Replacement battery(ies) must meet or exceed the following recommended capacities¹ at -18 °C (0 °F):

Specification	
12-Volt System—Minimum Battery Capacity—Cold Cranking	
Amps.....	640 Minimum
Reserve Capacity (Minutes).....	285 Minimum

¹ Total recommended capacity based on batteries connected in series or parallel.

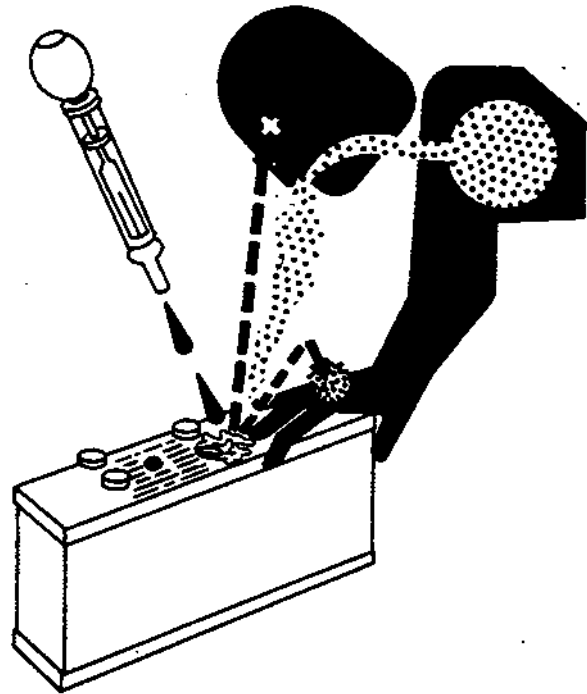

Sulfuric Acid

24-Volt System—Minimum Battery Capacity—Cold Cranking	
Amps.....	570 Minimum
Reserve Capacity (Minutes).....	275 Minimum

ZE59858,0000016 -19-28JUL14-2/2

T5203—UN—23AUG88

Changing Engine Oil and Replacing Filter

IMPORTANT: Changing engine oil and filter every 500 hours or 12 months depends on the following requirements:

- Engine equipped with an oil pan that allows capacity for this extended drain interval.
- Use of premium oil John Deere Plus-50, API CJ-4, ACEA E9, or ACEA E6.
- Perform engine oil analysis to determine the actual extended service life of API CJ-4, ACEA E9, or ACEA E6 oils.
- Use of the approved John Deere oil filter.
- Use of Ultra Low Sulfur Diesel (ULSD) fuel with sulfur content less than 0.0015% (15 mg/kg) is required.

The oil and filter change interval is reduced if ANY of the above listed requirements are not followed.

NOTE: During the initial operation of a new or rebuilt engine with Break-In Plus, change the oil and filter between a minimum of 100 hours and a maximum of up to 500 hours.

NOTE: Service intervals depend on sulfur content of the diesel fuel, oil pan capacity, engine power, and the oil and filter used. For more information, see Diesel Engine Oil and Filter Service Intervals in the Fuels, Lubricants, and Coolants Section.

OILSCAN™ or OILSCAN PLUS™ is a John Deere sampling program to help you monitor machine performance and identify potential problems before they cause serious damage. OILSCAN™ and OILSCAN PLUS™ kits are available from your John Deere engine distributor or servicing dealer. Oil samples should be taken prior to the oil change. Refer to instructions provided with kit.

*OILSCAN is a trademark of Deere & Company.
OILSCAN PLUS is a trademark of Deere & Company.*

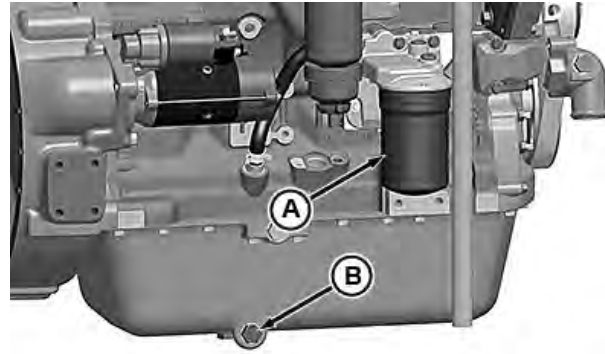

Oil Filter

A—Oil Filter

B—Oil Pan Drain Plug

IMPORTANT: Engine oil and metal surfaces of engine may be hot to the touch after shutdown. Use care to prevent burns.

1. Run engine approximately 5 minutes to warm up oil. Shut engine off.

NOTE: Drain plug location may vary, depending on the application.

2. Remove oil pan drain plug (B).
3. Drain crankcase oil from engine while warm.
4. Install oil pan drain plug with a new O-ring and tighten to specifications.

Specification

Oil Pan Drain Plug (Stamped Steel Pan)—Torque.....	40 N·m (30 lb.-ft.)
Oil Pan Drain Plug (Cast Pan)—Torque.....	48 N·m (35 lb.-ft.)

Continued on next page

ZE59858,0000017 -19-11AUG14-1/2

RG26252—UN—30JUL14

5. Remove oil filter. Discard oil filter.
6. Apply clean engine oil to the new filter at the inner (B) and outer (C) seals and to filter threads.
7. Wipe both sealing surfaces of the header (D and E) with a clean rag. Ensure notches in dust seal (F) are properly installed in the slots in the housing. Replace dust seal if damaged.

IMPORTANT: When installing filter element, HAND TIGHTEN only. A filter wrench may be used for REMOVAL ONLY. Be sure notches in dust seal (F) are properly installed in the slots in the housing.

8. Install and tighten oil filter by hand until firmly against dust seal (F). DO NOT apply an extra 3/4 to 1-1/4 turn after gasket contact, as done with standard filters.
9. Fill engine crankcase with correct John Deere engine oil through oil filler cap on either side of engine depending on engine application. (See [Diesel Engine Oil — Interim Tier 4, Final Tier 4, Stage IIIB, and Stage IV](#) in Fuels, Lubricants, and Coolant Section for determining correct engine oil.)

To determine the correct oil fill quantity for your engine, see [Engine Crankcase Oil Fill Quantities](#) in the Specifications Section of this manual.

NOTE: Crankcase oil capacity may vary slightly. ALWAYS fill crankcase within crosshatch marks on dipstick. DO NOT overfill.

10. Start engine and run to check for possible leaks.
11. Stop engine and check oil level after 10 minutes. Oil level reading should be within crosshatch marks on dipstick.



Oil Filter Seals

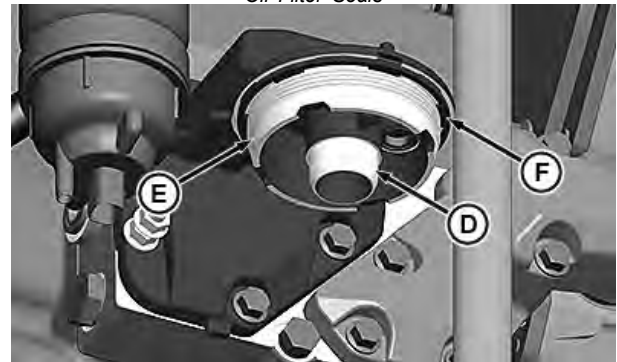

Oil Filter Header

- B—Inner Seal
- C—Outer Seal
- D—Sealing Surface On Header
- E—Sealing Surface On Header
- F—Dust Seal

ZE59858,0000017 -19-11AUG14-2/2

Visually Inspecting Coolant Pump

NOTE: Cooling pump drive pulley is removed for clarity purposes.

1. Coolant leakage indicates a damaged front seal. Inspect weep hole (A) for coolant leakage.
2. Replace complete coolant pump assembly if leakage is detected. A slight weeping of coolant is normal. If enough coolant leaks from the weep hole that it drips from the engine, the coolant pump assembly should be replaced. Individual repair parts are not available.

A—Weep Hole



ZE59858,0000018 -19-30JUL14-1/1

Checking Open Crankcase Vent (OCV)

Inspect OCV hoses (A, B, and C) for worn, cracked, leaking, or bulging.

Check hose clamps (D, E, and F) for good clamp tension.

Replace any worn or damaged parts.

- | | |
|-------------------|--------------------------|
| A—OCV Inlet Hose | D—Clamp — Inlet Hose |
| B—Air Outlet Hose | E—Clamp — Oil Drain Hose |
| C—Oil Drain Hose | F—Clamp — Outlet Hose |

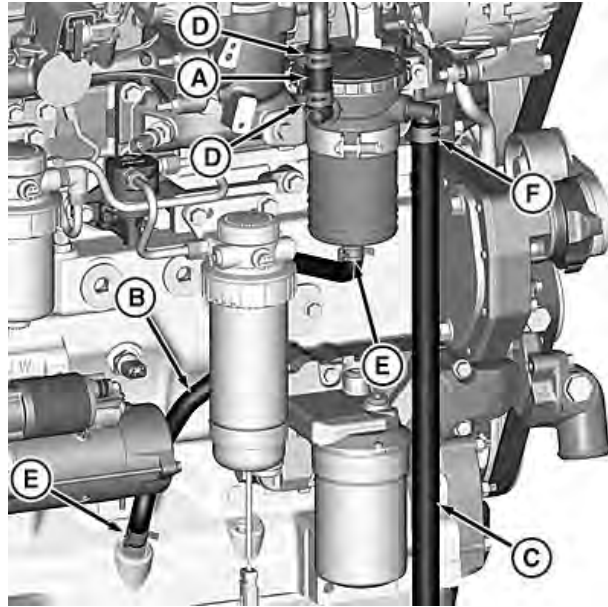

RG20672—UN—11JUL11

ZE59858,0000019 -19-30JUL14-1/1

Removing and Installing Fuel Filters

Engines are equipped with dual fuel filters: a primary filter with water bowl, and a final filter. Both filters are replaced at the same 500 hour or 12 months interval.

⚠ CAUTION: Escaping fluid under pressure can penetrate the skin causing serious injury. Relieve pressure before disconnecting fuel or other lines. Tighten all connections before applying pressure. Keep hands and body away from pinholes and nozzles which eject fluids under high pressure. To search for leaks use a piece of cardboard or paper. Do not use your hand.

If any fluid is injected into the skin, it must be surgically removed within a few hours by a doctor familiar with this type injury or gangrene may result. Doctors unfamiliar with this type of injury may call the Deere & Company Medical Department in Moline, Illinois, or other knowledgeable medical source.

IMPORTANT: Replace fuel filter elements anytime audible alarm sounds and diagnostic trouble

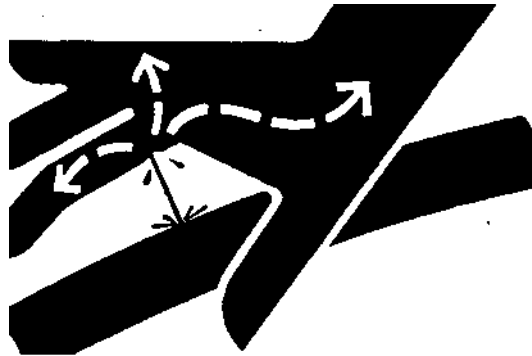

High-Pressure Fluids

codes (DTCs) indicate plugged fuel filters (low fuel pressure). If no alarm sounds during the 12 month or after 500 hours service interval, replace elements.

X9811—UN—23AUG88

Continued on next page

ZE59858,000001A -19-14AUG14-1/3

Remove and Install Primary Fuel Filter Element

NOTE: For applications other than OEM, refer to the application operator's manual for proper servicing, hourly replacement intervals, and filter locations.

NOTE: Both the primary and the final fuel filter elements must be replaced at the same time.

1. Thoroughly clean filter header (A) and surrounding area to prevent dirt and debris from entering fuel system.
2. Connect a hose to filter drain valve (F) on bottom of filter and drain all fuel from filter canister.
3. Disconnect water-in-fuel sensor connector (E).
4. Remove fuel filter element (C).
5. Place new O-ring (B) on filter element.
6. Apply a thin film of fuel on O-ring.

IMPORTANT: Do not fill the new filter with fuel before installing. This could contaminate the fuel system with unfiltered fuel.

7. Install new filter and tighten until the top portion of the filter contacts the filter header assembly.
8. Reconnect water-in-fuel sensor connector.

- | | |
|--------------------------------------|---|
| A—Primary Fuel Filter Header | D—Sediment Bowl |
| B—O-rings | E—Water-in-Fuel Sensor Connector |
| C—Primary Fuel Filter Element | F—Drain Valve |

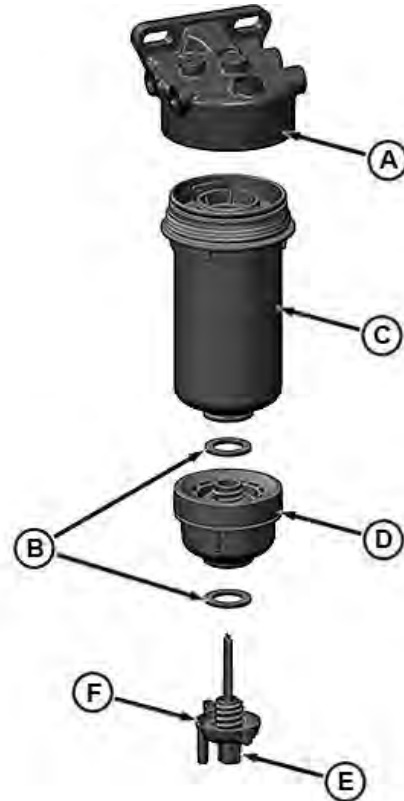

Replace primary fuel filter

RG26246—UN—14AUG14

Continued on next page

ZE59858,000001A -19-14AUG14-2/3

Remove and Install Secondary Fuel Filter Element

NOTE: For applications other than OEM, refer to the application operator's manual for proper servicing, hourly replacement intervals, and filter locations.

1. Thoroughly clean filter header (B) and surrounding area to prevent dirt and debris from entering fuel system.
2. Loosen and remove fuel filter element (A).
3. Apply a thin film of fuel on packing.

IMPORTANT: Do not fill the new filter with fuel before installing. This could possibly contaminate the fuel system with unfiltered fuel.

4. Install new filter and tighten until the top portion of the filter contacts the filter header assembly.

NOTE: For electronic fuel pump: To prime the fuel system before starting engine. Turn ignition key to ON for 60 seconds.

NOTE: For mechanical fuel pump: To prime the fuel system before starting engine. Open bleed vent

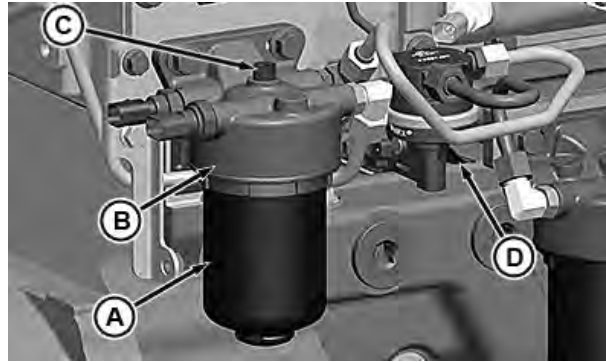

Replace Secondary Fuel Filter Element

- | | |
|---------------------------------|--------------------|
| A—Secondary Fuel Filter Element | C—Bleed Vent Screw |
| B—Secondary Fuel Filter Header | D—Primer Lever |

screw, pump primer lever until fuel flows out of bleed vent screw, then tighten bleed vent screw securely.

ZE59858,000001A -19-14AUG14-3/3

RG26322—UN—13AUG14

Checking Belt Wear

NOTE: While belt is loosened, inspect pulleys and bearings. Rotate and feel for hard turning or any unusual sounds. If pulleys or bearings need replacement, see your John Deere dealer.

The belt tensioner is designed to operate within the limit of arm movement provided by the cast stops when correct belt length and geometry are used.

Visually inspect cast stops on belt tensioner (A) assembly.

If the tensioner stop on swing arm is hitting the fixed stop, check mounting brackets (alternator, belt tensioner, idler pulley, etc.) and the belt length.

- Verify belt grooves mate correctly with all pulleys
- Inspect for excessive cracks
- Inspect for glazing
- Inspect for tears or cuts

Replace belt as needed based on wear and belt condition. Use correct belt routing during installation (see [Replacing Fan Belt](#) in the Service As Required Section).

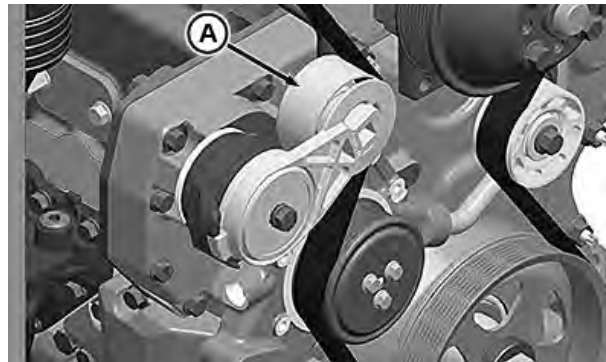

A—Belt Tensioner Assembly

ZE59858,000001B -19-30JUL14-1/1

RG26255—UN—30JUL14

Checking Tensioner Spring Tension

A belt tension gauge will not give an accurate measure of the belt tension when automatic spring tensioner is used. Measure tensioner spring tension using a torque wrench and procedure outlined below:

1. Release tension on belt using a long-handled 1/2 inch drive tool in tensioner arm. Remove belt from pulleys.
2. Release tension on tensioner arm and remove drive tool.
3. Put a mark (A) on swing arm of tensioner as shown.
4. Measure 21 mm (0.83 in.) from mark (A) and put a mark (B) on tensioner mounting base.

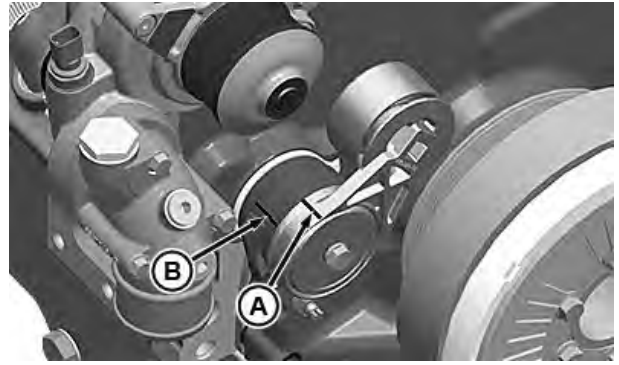

Checking Belt Tension Spring Tension

A—Mark

B—Mark

ZE59858,000001C -19-29JUL14-1/2

RG24039 —UN—07AUG13

5. Rotate the swing arm using a torque wrench until marks (A and B) are aligned.
6. Record torque wrench measurement and compare with specification below. Replace tensioner assembly as required.

Specification

Spring—Tension..... 18—22 N·m (13—16 lb.-ft.)

A—Mark

B—Mark

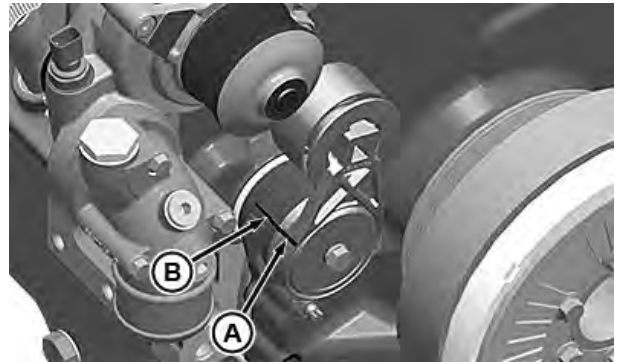

Checking Belt Tensioner Spring Tension

ZE59858,000001C -19-29JUL14-2/2

RG24040 —UN—07AUG13

Checking Cooling System

CAUTION: Explosive release of fluids from pressurized cooling system can cause serious burns.

Shut off engine. Only remove filler cap when cool enough to touch with bare hands. Slowly loosen cap to first stop to relieve pressure before removing completely.

IMPORTANT: Air must be expelled from cooling system when system is refilled. Loosen temperature sending unit fitting at rear of cylinder head or plug in thermostat housing to allow air to escape when filling system. Retighten fitting or plug when all the air has been expelled. Cooling system must be free of air by time engine coolant temperature reaches 80 °C (176 °F) or damage to EGR cooler (if equipped) may result.



High Pressure Fluids

1. Check entire cooling system for leaks. Tighten all clamps securely.
2. Thoroughly inspect all cooling system hoses for hard, flimsy, or cracked conditions. Replace hoses if any of the above conditions are found.

RK80614,000002D -19-11JUL13-1/1

TS281 —UN—15APR13

Pressure Testing Cooling System

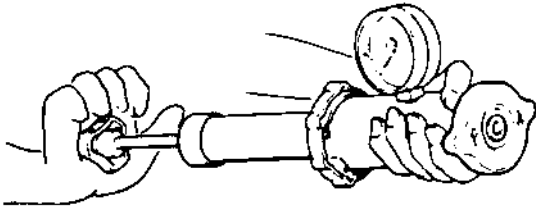

Test Radiator Cap

RG6657—UN—20JAN93

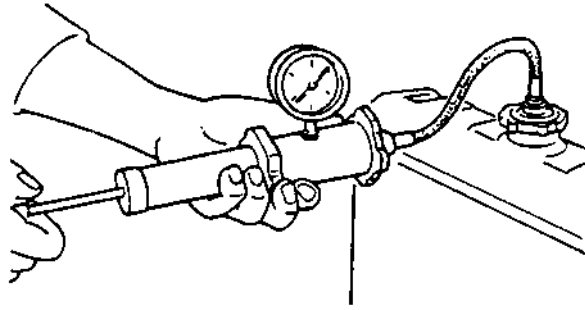

Test Cooling System

RG6658—UN—20JAN93

CAUTION: Explosive release of fluids from pressurized cooling system can cause serious burns.

Shut off engine. Only remove filler cap when cool enough to touch with bare hands. To relieve pressure before completely removing, slowly remove pressure cap and allow pressure to relieve before completely removing cap.

Test Radiator Cap

1. Remove radiator cap and attach to D05104ST Tester, or similar, as shown.
2. Pressurize cap to following specifications.¹ Gauge should hold pressure for 10 seconds within the normal range if cap is acceptable.

Specification

Radiator Cap—Maximum Pressure..... 124 kPa (1.24 bar) (18 psi)

If gauge does not hold pressure, replace radiator cap.

3. Remove the cap from gauge, turn it 180°, and retest cap. This verifies that the first measurement was accurate.

Test Cooling System for Leaks

NOTE: Engine should be warmed up to test overall cooling system for leaks.

¹Test pressures recommended are for all Deere OEM cooling systems. On specific vehicle applications, test cooling system and pressure cap according to the recommended pressure for that vehicle.

1. Allow engine to cool, then carefully remove radiator cap.
2. Fill radiator with coolant to the normal operating level.
3. Connect gauge and adapter to radiator filler neck, or expansion tank. Pressurize cooling system to the following specifications¹.

Specification

Cooling System—Maximum Pressure..... 124 kPa (1.24 bar) (18 psi)

4. With pressure applied, check all cooling system hose connections, radiator, and overall engine for leaks.

If leakage is detected, correct as necessary and pressure test system again.

If no leakage is detected, but the gauge indicated a drop in pressure, coolant may be leaking internally within the system or at the block-to-head gasket. Have your servicing dealer or distributor correct this problem immediately.

Checking and Adjusting Engine Speeds

Use tachometer on the diagnostic gauge (A) to verify engine speeds. (See Engine Power and Speed Rating Specifications in the Specifications Section for engine speed specifications.) If engine speed adjustment is required, see your authorized servicing dealer or engine distributor.

A—Diagnostic Gauge

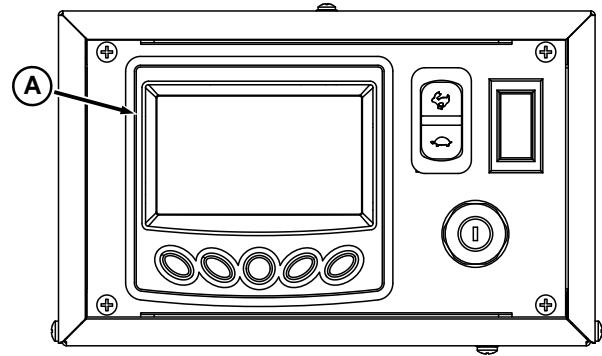

RG22413—UN—27AUG13

RK80614,0000030 -19-16DEC13-1/1

Checking Engine Mounts

Engine mounting is the responsibility of the Original Equipment Manufacturer. Follow manufacturer's guidelines for mounting specifications.

IMPORTANT: Use only Grade SAE 8 or higher grade of hardware for engine mounting.

1. Check the engine mounting brackets (A), vibration isolators, and mounting bolts on support frame and engine block for tightness. Tighten as necessary.
2. Inspect overall condition of vibration isolators, if equipped. Replace isolators, as necessary, if rubber has deteriorated or mounts have collapsed.

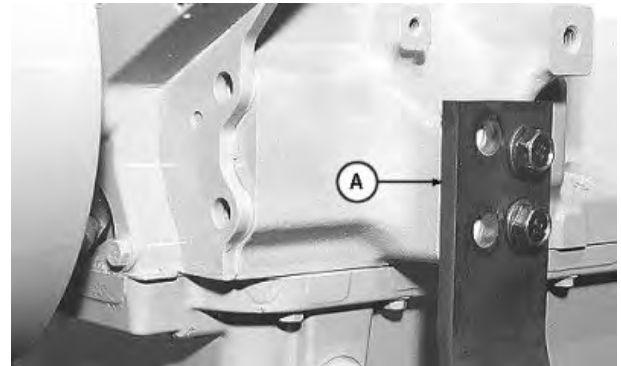

Engine Mounting

A—Mounting Bracket

RG9905—UN—06JAN99

RK80614,0000031 -19-11JUL13-1/1

Checking Engine Ground Connection

Check engine ground connection to be sure that it is secure and clean. This will prevent electrical arcing which can damage engine.

Verify engine to frame ground.

Verify battery ground to frame.

Verify Engine Control Unit to ground (Remote Mount).

RK80614,0000033 -19-11JUL13-1/1

Lubrication & Maintenance — 1500 Hours

Changing Open Crankcase Ventilation (OCV) Filter

Service checks of the OCV include checking and/or replacement of worn, cracked, leaking, or bulging hoses and for good clamp tension on all hose ends.

Expectation for minimal service interval will be at least 1500 hours or when the service indicator light comes on or as indicated by the diagnostic gauge.

1. Remove cap (A).
2. Remove OCV filter from canister.
Discard old OCV filter.
3. Install new OCV filter.
4. Install cap (A).

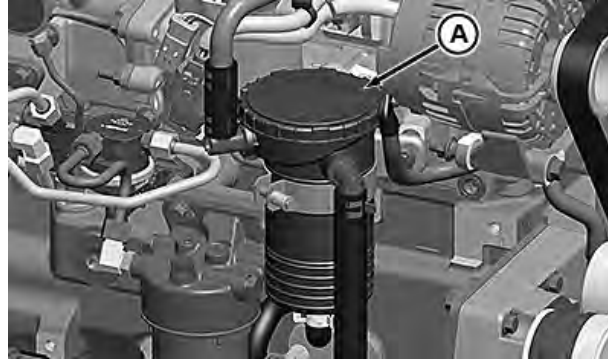

Changing OCV

A—Cap

RG26250—UN—30JUL14

ZE59858,000001E -19-30JUL14-1/1

Access DEF Dosing Unit

See your application manual for information on accessing the DEF dosing unit.

ZE59858,000008D -19-20NOV17-1/1

Changing Diesel Exhaust Fluid (DEF) Dosing Unit Filter

CAUTION: Avoid contact with eyes. In case of contact, immediately flush eyes with large amounts of water for a minimum of 15 minutes. Reference the Materials Safety Data Sheet (MSDS) for additional information.

IMPORTANT: If DEF is spilled or contacts any surface other than the storage tank, immediately clean the surface with clear water. DEF is corrosive to painted and unpainted metallic surfaces and can distort some plastic and rubber components.

Spilled DEF, if left to dry or if only wiped away with a cloth, leaves a white residue. Improperly cleaned DEF spill can interfere with diagnosis of Selective Catalytic Reduction (SCR) system leakage problems.

NOTE: DEF dosing unit filter and tank header suction screen must be replaced together every 1500 hours or 36 months, whichever occurs first.

NOTE: Servicing DEF dosing unit filter may require removing additional covers or components. See Access DEF Dosing Unit for location information.

1. Remove DEF dosing unit filter cover (A).
2. Remove and discard DEF dosing unit filter equalizing element (B).

NOTE: DEF dosing unit filter tool (C) is supplied with replacement filter.

3. Insert “Black” end of DEF dosing unit filter tool (C) into DEF dosing unit filter (D) until CLICK is felt or heard indicating DEF dosing unit filter tool is fully engaged.

NOTE: A tool such as a screwdriver can be inserted into DEF dosing unit filter tool slot to assist removal.



DEF Dosing Unit Filter

- | | |
|---|--|
| A—DEF Dosing Unit Filter Cover | C—DEF Dosing Unit Filter Tool (supplied with new filter) |
| B—DEF Dosing Unit Filter Equalizing Element | D—DEF Dosing Unit Filter |

4. Pull DEF dosing unit filter tool and DEF dosing unit filter from DEF dosing unit. Discard DEF dosing unit filter and DEF dosing unit filter tool.
5. Clean DEF dosing unit threads and mating surfaces with distilled water.
6. Lubricate DEF filter O-rings with clean DEF. Carefully insert DEF dosing unit filter into DEF dosing unit.
7. Install new DEF dosing unit filter equalizing element into DEF dosing unit filter.
8. Install DEF dosing unit filter cover and tighten to specification.

Specification

DEF Dosing Unit Filter Cover—Torque.....	23 N·m (204 lb-in)
--	-----------------------

DX,DEF,CHANGE,FILT -19-15AUG17-1/1

Access DEF Tank Header

See your application manual for information on accessing the DEF tank header.

EJ20264,00002E7 -19-20NOV17-1/1

Replace Diesel Exhaust Fluid (DEF) Tank Header Suction Screen

DEF Tank Header Identification

NOTE: Accessing DEF tank header may require removing additional covers or components. See *Access DEF Tank Header* for location information.

Type A DEF tank header has one wiring harness connection (A). Type B DEF tank header has two wiring harness connections (B). Refer to the procedure that is applicable to your DEF tank header.

A—Type A DEF Tank Header (one electrical connection) B—Type B DEF Tank Header (two electrical connections)

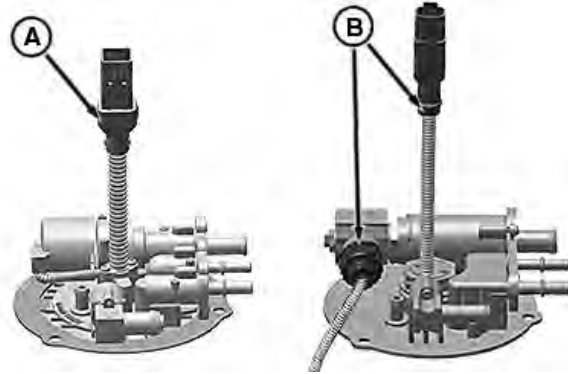

DEF Tank Header Identification

DX,DEF,REPL,THSCREEN -19-08DEC17-1/12

RG29623—UN—18JUL17

Replace Type A DEF Tank Header Suction Screen

CAUTION: Avoid contact with eyes. In case of contact, immediately flush eyes with large amounts of water for a minimum of 15 minutes. Reference the Materials Safety Data Sheet (MSDS) for additional information.

IMPORTANT: If DEF is spilled or contacts any surface other than the storage tank, immediately clean the surface with clear water. DEF is corrosive to painted and unpainted metallic surfaces and can distort some plastic and rubber components.

Spilled DEF, if left to dry or if only wiped away with a cloth, leaves a white residue. Improperly cleaned DEF spill can interfere with diagnosis of Selective Catalytic Reduction (SCR) system leakage problems.

NOTE: DEF tank header suction screen must be replaced every 1500 hours or 36 months, whichever occurs first. The DEF dosing unit filter must be replaced at the same time.

1. Clear all debris from area around DEF tank header.

CAUTION: Explosive release of fluids from pressurized cooling system can cause serious burns. Before disconnecting coolant hoses, wait until engine coolant is cool enough to touch the radiator or surge tank cap with bare hands. Slowly loosen radiator or surge tank cap to first stop to relieve pressure.

IMPORTANT: Cap and plug all lines and fittings to prevent contamination. Coolant in DEF

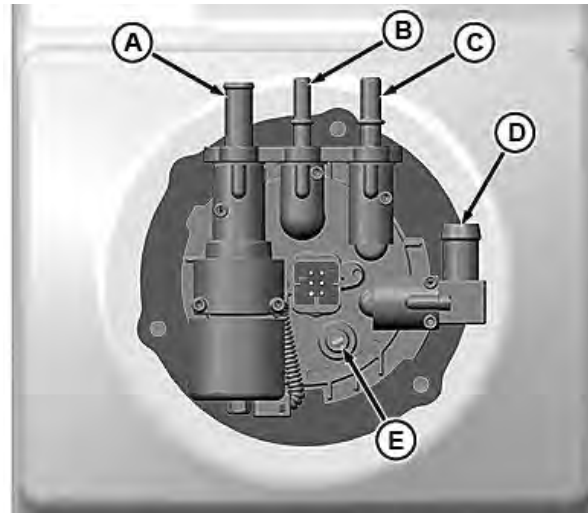

DEF Tank Header Fittings

A—Coolant Outlet Fitting D—Coolant Inlet Fitting
B—DEF Return Line Fitting E—Vent Line Fitting
C—DEF Supply Line Fitting

causes Selective Catalytic Reduction (SCR) system performance issues.

2. Disconnect coolant hoses from fittings (A and D).
3. Disconnect DEF return and supply lines from fittings (B and C).
4. Disconnect DEF tank header electrical connector.
5. Remove vent hose from fitting (E).

Continued on next page

DX,DEF,REPL,THSCREEN -19-08DEC17-2/12

RG29624—UN—19JUL17

6. Remove cap screws from DEF tank header locking ring (A).
7. Remove DEF tank header (C) from tank.
8. Remove O-rings (B) and inspect for damage.
9. Replace O-rings (B) if necessary.

A—DEF Tank Header Locking Ring
B—O-Ring (2 used)
C—DEF Tank Header

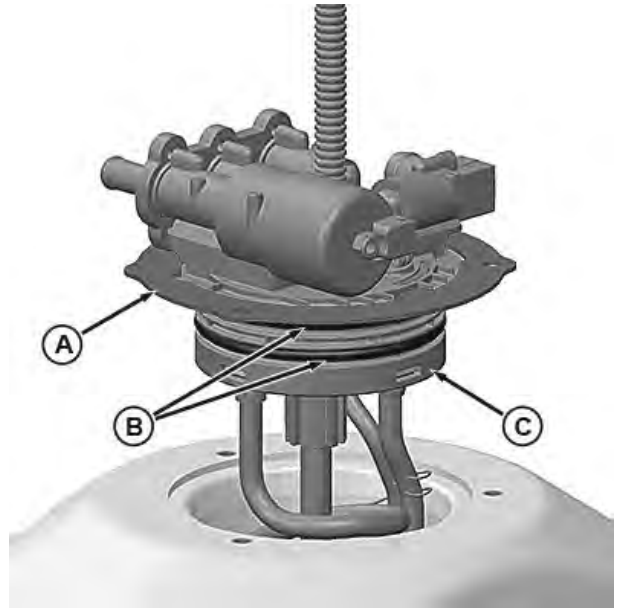

DEF Tank Header

DX,DEF,REPL,THSCREEN -19-08DEC17-3/12

RG29625—UN—25JUL17

10. Remove screw (A) that secures suction screen (B) to suction tube (C).
11. Remove suction screen (B).
12. Install suction screen (B) to suction tube (C).
13. Install screw (A) and tighten to specification.

Specification

DEF Suction Screen
 Screw—Torque.....1 N·m
 (11 lb·in)

A—Screw
B—Suction Screen
C—Suction Tube

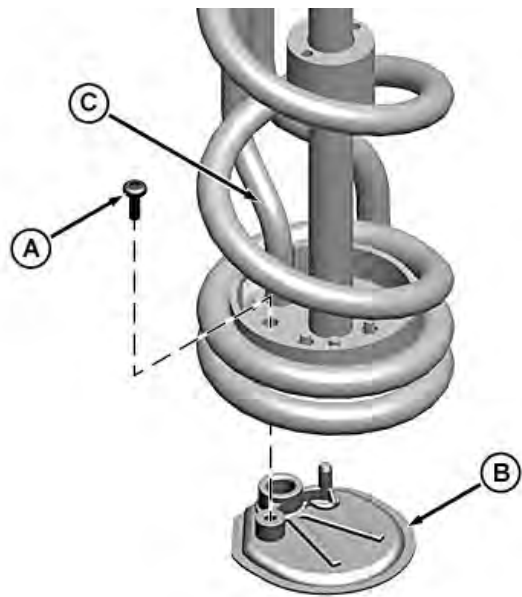

DEF Suction Screen

Continued on next page

DX,DEF,REPL,THSCREEN -19-08DEC17-4/12

RG23672—UN—01JUL13

- 14. Lubricate O-rings (B) with clean DEF.
- 15. Insert DEF header into tank and align holes on locking ring (A) with holes in tank.

A—DEF Tank Header Locking Ring
 B—O-Ring (2 used)
 C—DEF Tank Header

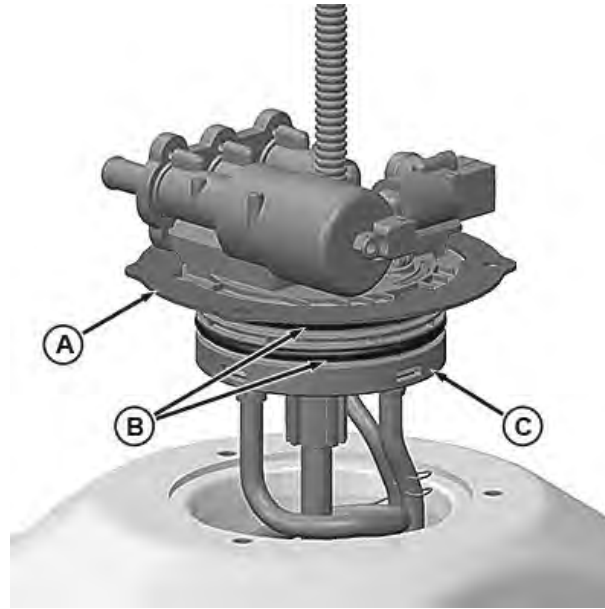

DEF Tank Header

DX,DEF,REPL,THSCREEN -19-08DEC17-5/12

RG29825 —UN—25JUL17

IMPORTANT: Prevent DEF leak, header, and lock ring damage. Ensure that alignment notches on the locking ring are properly aligned with plastic tabs on the header.

- 16. Install stainless steel cap screws into mounting holes and tighten to specification.

Specification

DEF Tank Header M6	
Cap Screw—Torque.....	9 N·m (80 lb·in)

A—Alignment Notch (2 used)

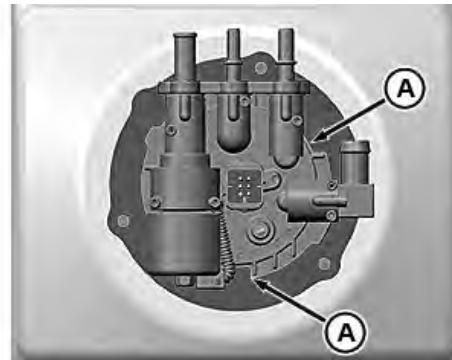

Alignment Notches

Continued on next page

DX,DEF,REPL,THSCREEN -19-08DEC17-6/12

RG25370 —UN—03APR14

17. Connect 9.5 mm (3/8 in) vent hose to fitting (E).
18. Connect 16 mm (5/8 in) coolant hose to coolant inlet fitting (D).
19. Connect 13 mm (1/2 in) coolant hose to coolant outlet fitting (A).

IMPORTANT: Push DEF line onto fitting until you hear a “click”, then lightly pull back to ensure that it is connected and locked in place.

NOTE: DEF supply and return lines have unique sized fittings.

20. Connect DEF return and supply lines to fittings (B and C).
21. Connect DEF tank header electrical connector.

- | | |
|-----------------------------------|---------------------------------|
| A —Coolant Outlet Fitting | D —Coolant Inlet Fitting |
| B —DEF Return Line Fitting | E —Vent Line Fitting |
| C —DEF Supply Line Fitting | |

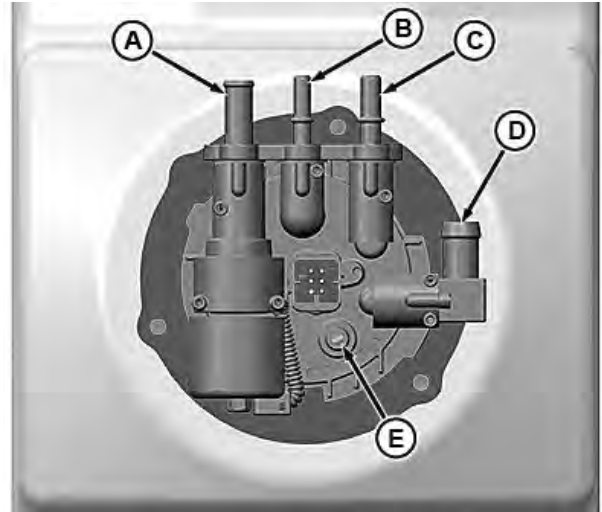

DEF Tank Header Fittings

RG29624 —UN—19JUL17

Continued on next page

DX,DEF,REPL,THSCREEN -19-08DEC17-7/12

Replace Type B DEF Tank Header Suction Screen

CAUTION: Avoid contact with eyes. In case of contact, immediately flush eyes with large amounts of water for a minimum of 15 minutes. Reference the Materials Safety Data Sheet (MSDS) for additional information.

IMPORTANT: If DEF is spilled or contacts any surface other than the storage tank, immediately clean the surface with clear water. DEF is corrosive to painted and unpainted metallic surfaces and can distort some plastic and rubber components.

Spilled DEF, if left to dry or if only wiped away with a cloth, leaves a white residue. Improperly cleaned DEF spill can interfere with diagnosis of Selective Catalytic Reduction (SCR) system leakage problems.

NOTE: DEF tank header suction screen must be replaced every 1500 hours or 36 months, whichever occurs first. The DEF dosing unit filter must be replaced at the same time.

1. Clear all debris from area around DEF tank header.

CAUTION: Explosive release of fluids from pressurized cooling system can cause serious burns. Before disconnecting coolant hoses, wait until engine coolant is cool enough to touch the radiator or surge tank cap with bare hands. Slowly loosen radiator or surge tank cap to first stop to relieve pressure.

IMPORTANT: Cap and plug all lines and fittings to prevent contamination. Coolant in DEF

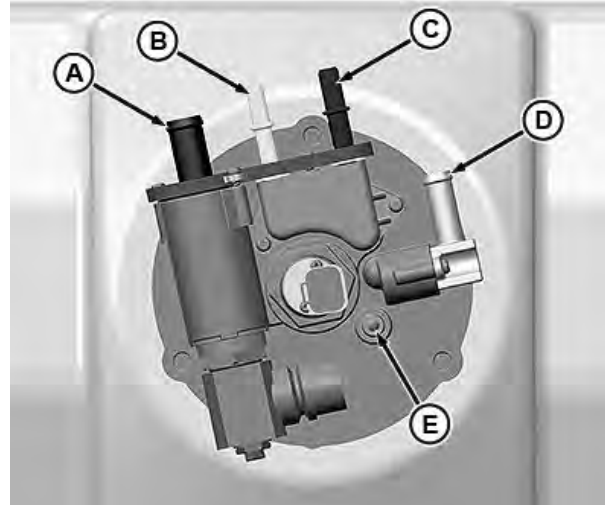

DEF Tank Header Fittings

A—Coolant Inlet Fitting D—Coolant Outlet Fitting
 B—DEF Return Line Fitting E—Vent Line Fitting
 C—DEF Supply Line Fitting

causes Selective Catalytic Reduction (SCR) system performance issues.

2. Disconnect coolant hoses from fittings (A and D).
3. Disconnect DEF return and supply lines from fittings (B and C).
4. Disconnect DEF tank header electrical connectors.
5. Remove vent hose from fitting (E).

DX,DEF,REPL,THSCREEN -19-08DEC17-8/12

6. Remove cap screws from DEF tank header mounting flange (A).
7. Remove DEF tank header (C) from tank.
8. Remove O-rings (B) and inspect for damage.
9. Replace O-rings (B) if necessary.

A—DEF Tank Header Mounting Flange C—DEF Tank Header
 B—O-Ring (2 used)

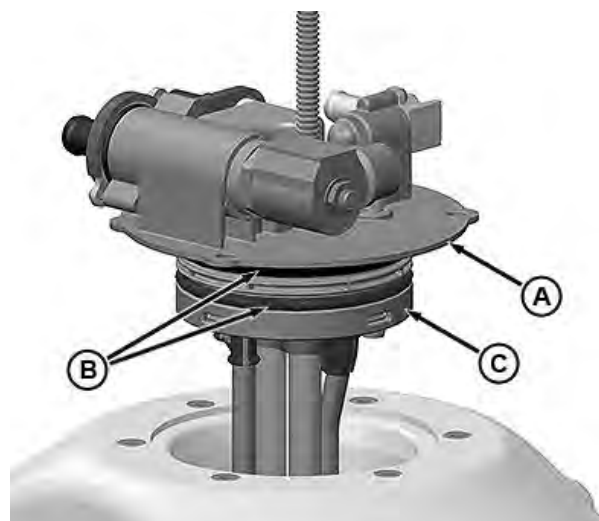

DEF Tank Header

Continued on next page

DX,DEF,REPL,THSCREEN -19-08DEC17-9/12

17. Connect 9.5 mm (3/8 in) vent hose to fitting (E).
18. Connect 16 mm (5/8 in) coolant hose to coolant inlet fitting (A).
19. Connect 13 mm (1/2 in) coolant hose to coolant outlet fitting (D).

IMPORTANT: Push DEF line onto fitting until you hear a “click”, then lightly pull back to ensure that it is connected and locked in place.

NOTE: DEF supply and return lines have unique sized fittings.

20. Connect DEF return and supply lines to fittings (B and C).
21. Connect DEF tank header electrical connectors.

A—Coolant Inlet Fitting	D—Coolant Outlet Fitting
B—DEF Return Line Fitting	E—Vent Line Fitting
C—DEF Supply Line Fitting	

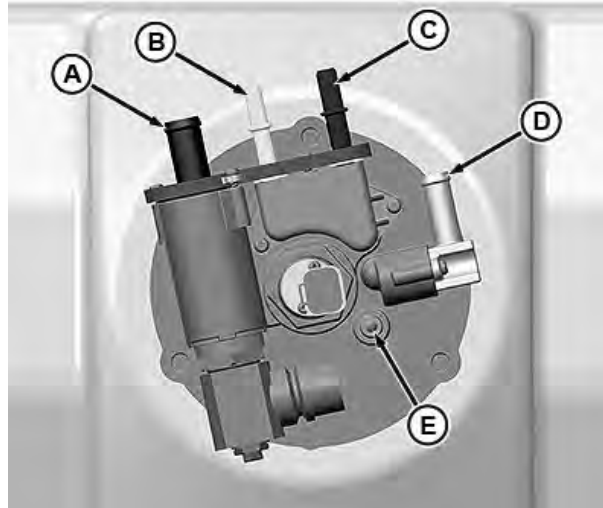

DEF Tank Header Fittings

RC29626—UN—19JUL17

DX,DEF,REPL,THSCREEN -19-08DEC17-12/12

Adjusting Valve Clearance

CAUTION: To prevent accidental starting of engine while performing valve adjustments, always disconnect **NEGATIVE** (—) battery terminal.

IMPORTANT: Valve clearance **MUST BE** checked and adjusted with engine **COLD**.

1. Remove rocker arm cover and crankcase ventilation tube.
2. Remove plastic plug (A) from engine timing/rotation hole (B) and timing pin hole (C).

IMPORTANT: Visually inspect contact surfaces of bridges, and rocker arm wear pads. Check all parts for excessive wear, breakage, or cracks. Replace parts that show visible damage.

Rocker arms that exhibit excessive valve clearance should be inspected more thoroughly to identify damaged parts.

3. Install JDG820 flywheel turning tool and JDG1571 timing pin.
4. Rotate engine with the flywheel turning tool until locking pin engages timing hole in flywheel.

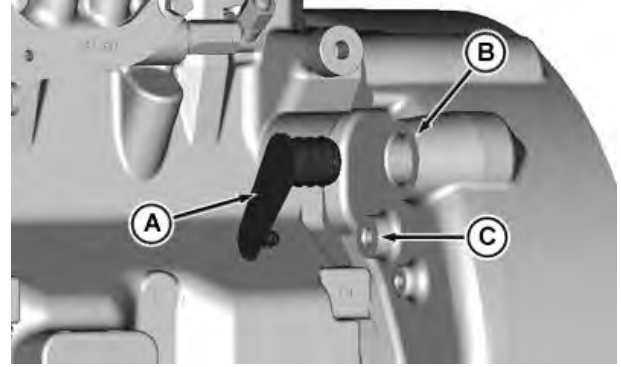

Bores to Insert Flywheel Turning Tool and Locking Pin

A—Plastic Plug
B—Flywheel Turning Tool Bore
C—Locking Pin Bore

NOTE: If the rocker arms for No. 1 (front) cylinder are loose, the engine is at No. 1 top dead center.

NOTE: If the rocker arms for No. 4 (rear) cylinder are loose, the engine is at No. 4 top dead center. Rotate the engine one full revolution (360°) to No. 1 top dead center.

Continued on next page

ZE59858,000001F -19-13AUG14-1/4

RG20596 —UN—03JUN11

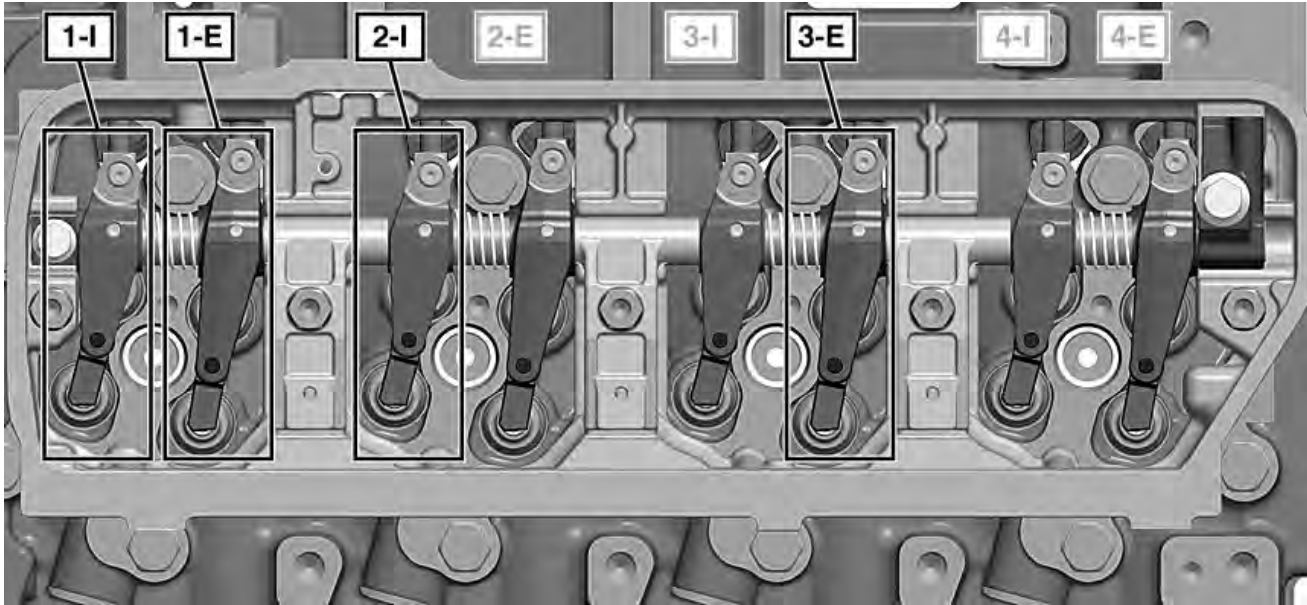

Valve Clearance Adjustment — #1 TDC

5. With engine locked at “TDC” of No. 1 piston compression stroke, use a bent feeler gauge to check valve clearance on No. 1 and 3 exhaust and No. 1 and 2 intake valves. Loosen lock nut (F) on rocker arm adjusting screw. Turn adjusting screw with a 4 mm hex key until feeler gauge slips with a slight drag. Hold the adjusting screw from turning and tighten lock nut to specifications

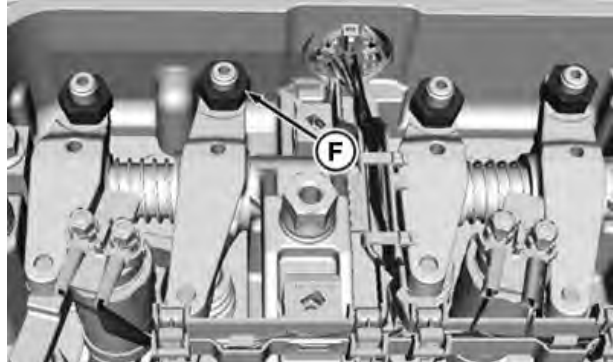

Rocker Arm Lock Nut

Specification

Intake Valve Clearance (Rocker Arm-to-Valve Bridge With Engine Cold)—Clearance.....	0.46 mm (0.018 in.)
Exhaust Valve Clearance (Rocker Arm-to-Valve Bridge With Engine Cold)—Clearance.....	0.53 mm (0.021 in.)
Valve Adjusting Screw Lock Nut—Torque.....	27 N·m (20 lb.-ft.)

F—Lock Nut

Recheck clearance again after tightening lock nut.
Readjust clearance as necessary.

Continued on next page

ZE59858,000001F -19-13AUG14-2/4

RG20492—UN—24JUN11

RG25615—UN—24APR14

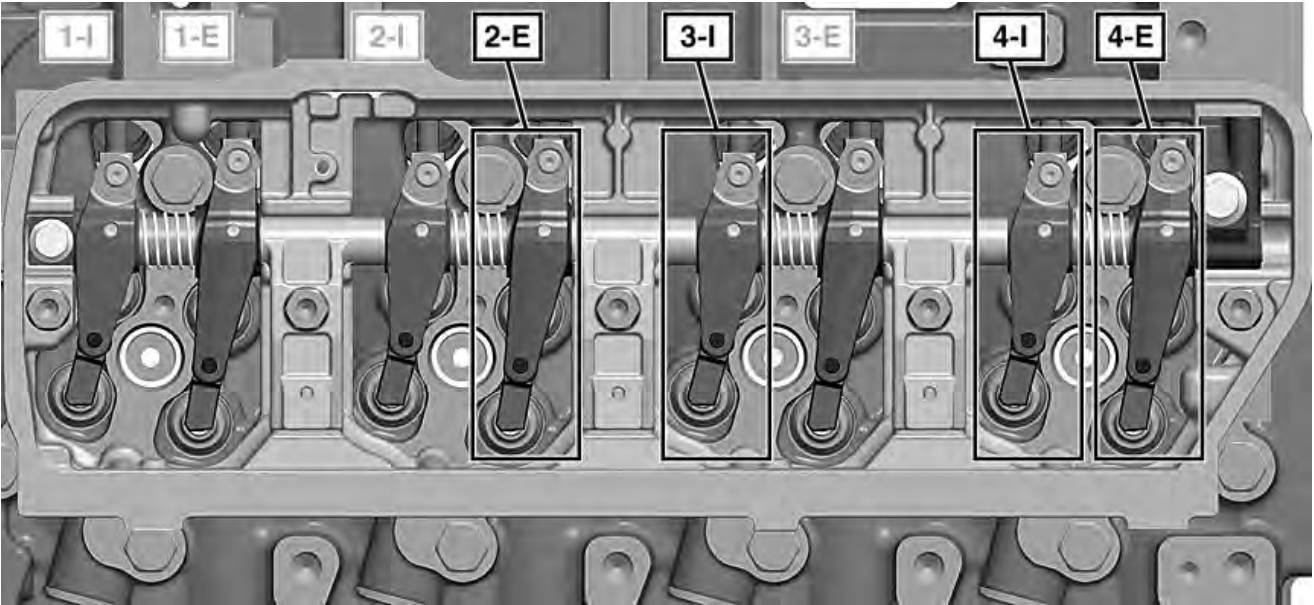

RG20493 —UN—24JUN11

Valve Clearance Adjustment — #4 TDC

6. Rotate flywheel 360° until No. 4 piston is at "TDC" of its compression stroke. Rocker arms for No. 4 piston should be loose.
7. Check and adjust valve clearance to the same specifications on for No. 2 and 4 exhaust and No. 3 and 4 intake valves.

ZE59858,000001F -19-13AUG14-3/4

8. Install rocker arm cover gasket.

IMPORTANT: When reinstalling rocker arm cover, inspect gasket for damage prior to reusing.

9. Tighten cap screws to specifications, in the sequence shown.

Specification

Rocker Arm Cover Cap
Screws—Torque.....11 N·m (97 lb.-in.)

10. Install vent tube to rocker arm cover.



RG25069 —UN—14FEB14

Rocker Arm Cap Screws Tightening Sequence

ZE59858,000001F -19-13AUG14-4/4

Testing Glow Plugs for Continuity

⚠ CAUTION: To prevent accidental starting of engine while performing this test, always disconnect **NEGATIVE (—)** battery terminal.

1. Remove glow plug wiring harness connector (C).
2. Using a multimeter, check resistance from terminal (B) to the outer body of glow plug (A).
If resistance is more than 10 Ohms, the glow plug is damaged and must be replaced.
3. If needed, install new glow plugs and torque to specifications.

Specification

Glow Plug—Torque..... 15 N·m (133 lb.-in.)

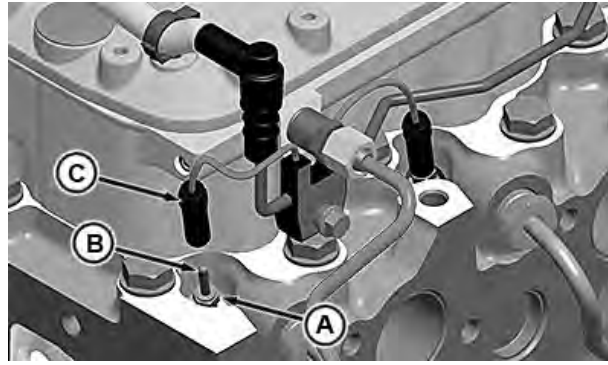

Check Glow Plug

A—Glow Plug
B—Terminal

C—Harness Connector

RG26311 —UN—13AUG14

ZE59858,0000020 -19-13AUG14-1/1

Flushing and Refilling Cooling System

⚠ CAUTION: Explosive release of fluids from pressurized cooling system can cause serious burns.

Shut off engine. Only remove filler cap when cool enough to touch with bare hands. Slowly remove the pressure cap and allow pressure to relieve before completely removing cap.

NOTE: If COOL-GARD II is not used, the drain interval is reduced to 2000 hours or 24 months of operation.

1. Pressure test entire cooling system and pressure cap if not previously done. (See [Pressure Testing Cooling System](#) in the Lubrication & Maintenance — 500 Hours/12 Months Section.
2. Slowly open the engine cooling system filler cap or radiator cap to relieve pressure and allow coolant to drain faster.



High-Pressure Fluids

Continued on next page

ZE59858.0000021 -19-12AUG14-1/2

T5281 —UN—15APR13

NOTE: Drain coolant from the lowest point in the cooling system. This location will vary by application.

3. Drain all coolant from engine block.
4. Open radiator drain valve. Drain all coolant from radiator.
5. Remove thermostats at this time, if not previously done. Install cover (without thermostats and seals) and tighten socket head cap screws to specifications.

Specification

Thermostat Cover —
 Socket Head Cap
 Screws—Torque..... 73 N·m (54 lb.-ft.)

6. Close all drain valves after coolant has drained.

⚠ CAUTION: Do not run engine longer than 10 minutes. Doing so may cause engine to overheat which may cause burns when radiator water is draining.

7. Fill the cooling system with clean water. Run the engine about 7 minutes to stir up possible contaminants or foreign particles.
8. Stop engine, pull off lower radiator hose and remove radiator cap. Immediately drain the water from system before contaminants or foreign particles settle.
9. After draining water, close drain valves. Install radiator cap, radiator hose, and clamp. Fill the cooling system with clean water and a heavy duty cooling system cleaner such as Restore or Restore Plus. Follow manufacturer's directions on label.
10. After cleaning the cooling system, drain cleaner and fill with water to flush the system. Run the engine about 7 minutes. Stop engine, remove radiator cap and drain water.
11. Close all drain valves on engine and radiator.
12. Perform Testing Thermostat Opening Temperature in the Lubrication & Maintenance — 6000 Hours/72 Months Section.



Engine Block Coolant Drain Plug—Right Side of Engine

A—Right Side of Engine Block Coolant Drain Plug

13. Install thermostats using a new gasket. Tighten thermostat cover socket head cap screws to specifications.

Specification

Thermostat Cover —
 Socket Head Cap
 Screws—Torque..... 73 N·m (54 lb.-ft.)

14. Add coolant to surge tank (See application manual for coolant volume).

Specification

4.5 L Engine—Coolant Capacity (Excluding Radiator)..... 8.5 L (9 qt.)

15. Run engine until it reaches operating temperature. This mixes the solution uniformly and circulates it through the entire system. The normal engine coolant temperature range is 85—103 °C (185—217 °F).
16. After running engine, check coolant level and entire cooling system for leaks.
17. Inspect the fan belt for wear and check belt tension. (See Checking Belt Wear in the Lubrication & Maintenance — 500 Hours/12 Months Section.

ZE59858,0000021 -19-12AUG14-2/2

RG26298 — UN—12AUG14

Testing Thermostat Opening Temperature

Removing Thermostats

⚠ CAUTION: Explosive release of fluids from pressurized cooling system can cause serious burns. **DO NOT** drain coolant until it has cooled below operating temperature. Always loosen radiator pressure cap or drain valve slowly to relieve pressure.



High Pressure Fluids

ZE59858,0000022 -19-18AUG14-1/4

T5281 —UN—15APR13

1. Visually inspect area around thermostat housing for leaks.
2. Remove radiator pressure cap and partially drain cooling system.
3. Remove three cap screws (C) and thermostat cover (B) clean and check cover for cracks or damage.
4. Remove both thermostats (A) from the housing.

A—Thermostats (2 Used)
B—Thermostat Cover

C—Cap Screws (3 Used)

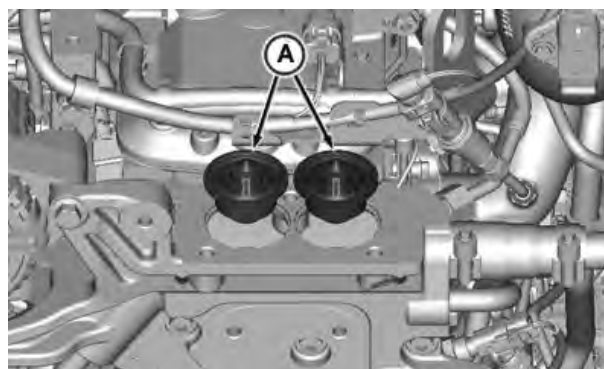
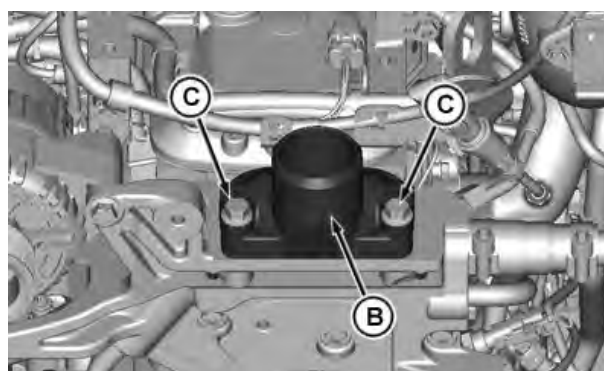

Removing Thermostats

Continued on next page

ZE59858,0000022 -19-18AUG14-2/4

RG20113 —UN—18MAR11

RG20112 —UN—18MAR11

Testing Thermostats Opening Temperature

NOTE: Perform the following test for both thermostats.

1. Visually inspect thermostats for corrosion or damage. Replace as a matched set, as necessary.

⚠ CAUTION: DO NOT allow thermostat or thermometer to rest against the side or bottom of container when heating water. Either may rupture if overheated.

2. Suspend thermostat and a thermometer in a container of water.
3. Stir the water as it heats. Observe opening action of thermostat and compare temperatures to specifications.

NOTE: Due to varying tolerances of different suppliers, initial opening and full open temperatures may vary slightly from specified temperatures.

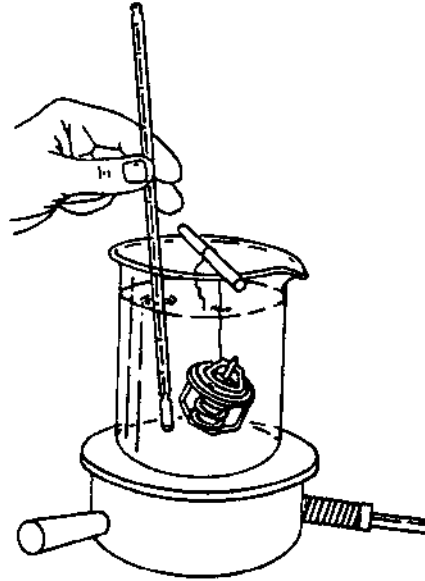

Testing Thermostat Opening Temperature

RC5971—UN—23NOV97

Specification

Thermostat

Opening—Temperature..... 85 °C—97 °C (185 °F—207 °F)

4. Remove thermostat and observe its closing action as it cools. In ambient air the thermostat should close completely. Closing action should be smooth and slow.
5. If any thermostat is defective, replace both thermostats.

Continued on next page

ZE59858,0000022 -19-18AUG14-3/4

Installing Thermostats

1. Install new rubber seal for each thermostat (A).
2. Install thermostats into housing (D).
3. Install thermostat cover (B) and tighten thermostat cover cap screws (C) to specifications.

Specification

Thermostat Cover Cap

Screw—Torque..... 73 N·m (54 lb.-ft.)

4. Fill cooling system and check for leaks.

IMPORTANT: Air must be expelled from cooling system when refilled.

A—Thermostats
B—Thermostat Cover

C—Cap Screws (3 Used)
D—Thermostat Housing

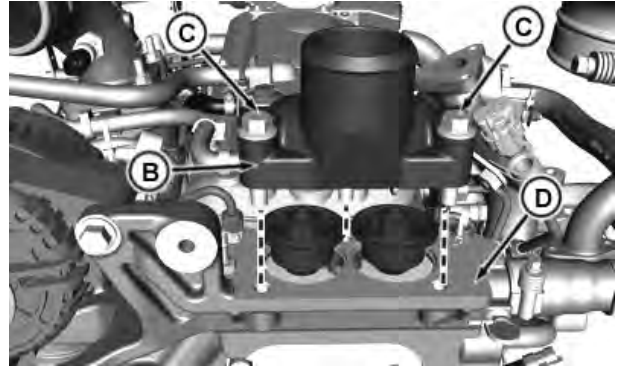
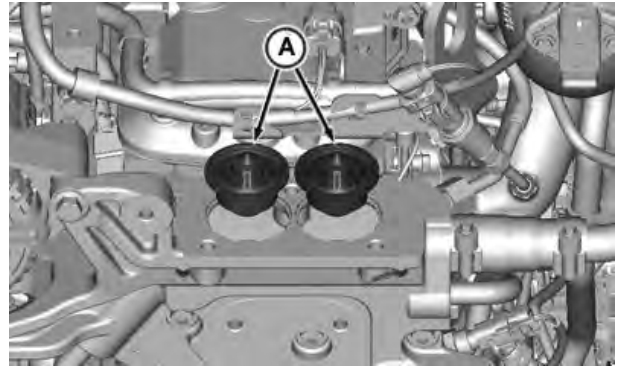

















Installing Thermostats

ZE59858,0000022 -19-18AUG14-4/4

RG20112 —UN—18MAR11

RG25248 —UN—12MAR14

Indicator	Active When	Operator Action	
DEF Indicator		1. DEF tank has approximately 10% or less remaining.	Fill DEF tank.
DEF And Warning Indicator	 	1. DEF tank has 0% measurable volume and machine performance is reduced. *DTC: 001761.18 will be present. 2. DEF system has lost its prime and machine performance is reduced. *DTC: 001761.08 will be present.	Fill DEF tank.
Engine Emissions System Malfunction Indicator		1. Engine emissions outside of normal operating range. 2. Engine emissions system fault.	Contact your service dealer.
Engine Emissions System Malfunction and Warning Indicator	 	1. Engine emissions outside of normal operating range. Machine performance will be reduced. 2. Engine emissions system fault. Machine performance will be reduced.	Contact your service dealer.
Engine Emissions Temperature Indicator		1. Engine gas temperature is high. 2. Exhaust filter cleaning is in process. If at all possible do not abort a Regen in progress.	Machine can be operated as normal. If operating in an area where high exhaust temperatures may be an issue, abort exhaust filter cleaning by using the disable feature. Too many aborted Regens will cause the need for a Parked or Recovery Regen.
Engine Emissions Temperature Indicator and Warning Indicator	 	Exhaust gas temperature is higher than expected. Machine performance is reduced.	Contact your service dealer.
Engine Emissions Temperature Indicator and Stop Indicator	 	Exhaust gas temperature is higher than expected. Machine performance is reduced.	Contact your service dealer.
Exhaust Filter Indicator		1. Soot level in the exhaust filter indicates need for an exhaust filter cleaning. *DTC: 003719.15 will be present. 2. Aftertreatment System Fault.	Enable auto exhaust filter cleaning to allow a cleaning cycle or begin a manual / parked cleaning. If exhaust filter cleaning is performed and indicator is still active: Contact your service dealer. 1200 RPM minimum speed required for AUTO Regen to start.
Exhaust Filter and Warning Indicator	 	1. Machine performance is reduced due to moderately high soot level. *DTC: 003719.16 will be present. 2. Aftertreatment System Fault. Machine performance will be reduced.	Begin a manual / parked cleaning. If filter cleaning is performed and indicator is still active: Contact your service dealer.
Exhaust Filter and Stop Indicator	 	1. Exhaust filter requires service. Machine performance is reduced due to extremely high soot level and a stop engine request is made. *DTC: 003719.00 will be present. 2. Aftertreatment System Fault. Machine performance is reduced.	Service the exhaust filter. Contact your service dealer. Recovery Regen required due to too many aborted or disabled Regens.
Auto Cleaning Disabled Indicator		Auto exhaust filter cleaning is disabled. If you need assistance enabling AUTO Regen please call (800) 562-8049 and ask for Technical Assistance. <i>*Diagnostic Trouble Codes (DTC)</i>	If possible, enable auto exhaust filter cleaning. Auto Regen is your Friend, please use it. This setting will allow the engine to clean the filter with no operator action as long as the engine speed is above 1200 RPM. Machine can operate as normal but will not idle below 1200 RPM until Regen is complete.